

CHAPTER 4. STORM SEWER SYSTEM DESIGN

CONTENTS

	Section Page ST-
EXECUTIVE SUMMARY	1
Purpose of the Chapter	1
Chapter Summary	1
Summary of Critical Design Criteria	2
Stormwater Flow – Pavement Encroachment and Curb Depth Standards for the Minor Storm, 10-yr Return Frequency	2
Stormwater Flow – Curb Depth and Street Inundation Standards for the Major Storm, 100-yr Return Frequency	3
Allowable Stormwater Flow Through Cross-Street/Intersection	3
Physical Constraints for Curb and Gutter	4
Physical Constraints for Roadside Swales	4
Inlet Types and Applicable Settings	4
Physical Constraints for Storm Drain Inlets / Junction Boxes	5
Inlet Spacing	5
Inlets Located in Sumps and “Flat” Grades	6
Inlet Clogging Factors	6
Storm Sewer Pipe Shape	6
Storm Sewer Pipe Material	7
Storm Sewer Pipe Physical and Operational Constraints	9
1.0 STREET DRAINAGE	10
1.1 Street Function and Classification	10
1.2 Design Considerations	10
1.3 Hydraulic Evaluation of Street Gutters and Swales	12
1.3.1 Evaluation Procedures	12
1.3.2 Curb and Gutter	13
1.3.2.1 Physical Constraints for Longitudinal Slope and Cross Slope	13
1.3.2.2 Gutters With Uniform Cross Slopes (i.e., Where Gutter Cross Slope = Street Cross Slope)	13
1.3.2.3 Gutters With Composite Cross Slopes (i.e., Where Gutter Cross Slope ≠ Street Cross Slope)	15
1.3.2.4 Allowable Gutter Hydraulic Capacity	16
1.3.3 Swale Sections (V-Shaped With the Same or Different Side Slopes)	17
2.0 STORM DRAIN INLETS	19
2.1 Inlet Functions, Types and Appropriate Applications	19
2.2 Design Considerations	21
2.3 Hydraulic Evaluation	22
2.3.1 Grate Inlets (On a Continuous Grade)	22
2.3.2 Curb-Opening Inlets (On a Continuous Grade)	26
2.3.2.1 Curb-Opening Inlet – Not Depressed	28
2.3.2.2 Curb-Opening Inlet – Depressed	28
2.3.3 Combination Inlets (On a Continuous Grade)	29
2.3.4 Slotted Inlets (On a Continuous Grade)	29
2.3.5 Inlets Located in Sumps	29
2.3.6 Inlet Clogging	32
2.4 Inlet Location and Spacing on Continuous Grades	34
2.4.1 Introduction	34
2.4.2 Design Considerations	34
2.4.3 Design Procedure	35
3.0 STORM SEWERS	36
3.1 Introduction	36

STORM SEWER SYSTEM DESIGN

3.2 Storm Sewer System Components	37
3.2.1 Inlets	37
3.2.2 Junction Boxes	37
3.2.3 Storm Sewer Pipe.....	37
3.2.4 Bends and Transitions	37
3.2.5 Outlets	37
3.3 Design Process, Considerations, and Constraints	38
3.3.1 Storm Sewer Pipe.....	38
3.3.1.1 Design Storm Accommodation	38
3.3.1.2 Size	38
3.3.1.3 Material	39
3.3.1.4 Manning’s Roughness Coefficients.....	39
3.3.1.5 Shape	40
3.3.1.6 Minimum Grades	40
3.3.2 Curb Inlet/Junction Boxes.....	40
3.3.3 Bends and Transitions	41
3.4 Storm Sewer Hydrology	42
3.4.1 Peak Runoff Prediction	42
3.5 Storm Sewer Hydraulics (Gravity Flow in Circular Conduits)	43
3.5.1 Flow Equations and Storm Sewer Sizing	43
3.5.2 Energy Grade Line and Head Losses	44
3.5.2.1 Losses at the Downstream Junction Box—Section 1 to Section 2	45
3.5.2.2 Losses in the Pipe, Section 2 to Section 3.	47
3.5.2.3 Losses at the Upstream Junction Box, Section 3 to Section 4	48
3.5.2.4 Juncture and Bend Losses at the Upstream Junction Box, Section 4 to Section 1.....	49
3.5.2.5 Transitions	52
3.5.2.6 Curved Storm Sewers.....	53
3.5.2.7 Losses at Storm Sewer Exit.....	53
4.0 REFERENCES	57

DRAINAGE CRITERIA MANUAL

TABLES

Table ST-1 — Pavement Encroachment and Curb Depth Standards for the Minor Storm, 10-yr Return Frequency	11
Table ST-2 — Street Inundation Standards for the Major Storm, 100-yr Return Frequency	11
Table ST-3 — Allowable Cross-Street/Intersection Flows	12
Table ST-4 — Manning's n Values For Street and Pavement Gutters (FHWA – HDS-3 1961)	14
Table ST-5 — Applicable Settings for Various Inlet Types	21
Table ST-6 — Splash Velocity Constants for Various Types of Inlet Grates (UDFCD USDCM 2002)	25
Table ST-7 — Sag Inlet Discharge Variables and Coefficients (Modified From Akan and Houghtalen 2002)	31
Table ST-8 — Clogging Coefficients and Clogging Factor to apply to Multiple Units (UDFCD USDCM 2002)	33
Table ST-9 — Manning's Roughness Coefficients, n for Storm Drains	40
Table ST-10 — Inlet / Junction Box Spacing Based on Storm Sewer Pipe Size	41
Table ST-11 — Inlet / Junction Box Sizing	41
Table ST-12 — Entrance Loss Coefficients for Outlet Control, Full or Partly Full Flow (FHWA – HDS-5 2005)	48
Table ST-13 — Bend Loss and Lateral Loss Coefficients (FHWA – HEC-22 2001)	51
Table ST-14 — Head Loss Expansion Coefficients (Ke) in Non-Pressure Flow (FHWA – HEC-22 2009)	52
Table ST-15 — Typical Values for Sudden Pipe Contractions (Kc) (FHWA – HEC-22 2009)	52

FIGURES

Figure ST-1 — Typical Gutter Section – Constant Cross Slope (VDOT Drainage Manual 2010)	14
Figure ST-2 — Typical Gutter Section – Composite Cross Slope (VDOT Drainage Manual 2010)	15
Figure ST-3 — Reduction Factor for Allowable Gutter Capacity	17
Figure ST-4 — Typical Street-Side Swale Sections—V-Shaped (UDFCD USDCM 2002)	18
Figure ST-5 — Types of Storm Drain Inlets (FHWA – HEC-22 2001)	20
Figure ST-6 — Grate Inlet Frontal Flow Interception Efficiency (FHWA – HEC-22 2009)	23
Figure ST-7 — Grate Inlet Side Flow Interception Efficiency (FHWA – HEC-22 2009)	26
Figure ST-8 — Curb-Opening and Slotted Drain Inlet Interception Efficiency (FHWA – HEC-22 2009)	27
Figure ST-9 — Depressed Gutter Section (FHWA – HEC-22 2009)	29
Figure ST-10 — Curb Opening Inlet Throat Type for Use in Design (FHWA – HEC 22 2009)	32
Figure ST-11 — A Storm Sewer-Junction Box Unit (UDFCD USDCM 2002)	46
Figure ST-12 — Hydraulic and Energy Grade Lines (UDFCD USDCM 2002)	46
Figure ST-13 — Bend Loss Coefficients (UDFCD USDCM 2002)	54
Figure ST-14 — Access Hole Benching Methods (UDFCD USDCM 2002)	55
Figure ST-15 — Angle of Cone for Pipe Diameter Changes (FHWA HEC-22 2009)	56

STORM SEWER SYSTEM DESIGN

EXECUTIVE SUMMARY

Purpose of the Chapter

The intent of this chapter of the *Manual* is to give concise, practical guidelines for the design of urban storm water collection and conveyance systems. Procedures and equations are presented for the hydraulic design of storm sewer systems, locating inlets and determining capture capacity and efficiency, and sizing storm sewers. In addition, examples are provided to illustrate the hydraulic design process. Spreadsheet solutions accompany the hand calculations for most example problems.

Chapter Summary

Proper sizing and placement of stormwater capture and conveyance structures is pivotal in the handling of stormwater runoff in urban areas. The primary function of stormwater collection and conveyance systems is to collect excess stormwater from street gutters, convey the excess stormwater through storm sewers and along the street right-of-way or drainage easements, and discharge it into a detention basin, water quality best management practice (BMP) or the nearest receiving water body (FHWA 1996). The main premise of urban stormwater systems is to minimize disruption to the natural drainage system, promote safe passage of vehicular traffic during minor storm events, maintain public safety and manage flooding during major storm events, preserve and protect the urban stream environment, and minimize capital and maintenance costs of the stormwater collection system. To ensure these measures are met, consistent and strategic use of accepted and proven design methodology for sizing and placing stormwater capture and conveyance structures is required. Within this section of the *Manual* the City of Rogers addresses specific stormwater system design methods and system requirements that have been deemed acceptable and compatible with the type of transportation system and stormwater system characteristic within the City.

Urban stormwater collection and conveyance systems are comprised of three primary components: (1) street gutters and roadside swales, (2) stormwater inlets, and (3) storm sewers (and appurtenances like manholes, junctions, bends and transitions, etc.). Street gutters and roadside swales collect runoff from the street (and adjacent areas) and convey the runoff to a stormwater inlet while maintaining the street's level-of-service.

Inlets collect stormwater from streets and other land surfaces, transition the flow into storm sewers, and often provide maintenance access to the storm sewer system. Storm sewers convey stormwater in excess of a street's or a swale's capacity along the right-of-way and discharge it into a stormwater management facility or a nearby receiving water body. All of these components must be designed properly to achieve the stormwater collection and conveyance system's objectives. This chapter of the *Manual* spells out the steps involved in the design and evaluation of the three primary components mentioned above.

DRAINAGE CRITERIA MANUAL

The design procedures presented in this chapter are based upon fundamental hydrologic and hydraulic design concepts. The design equations provided are well accepted and widely used. They are presented without derivations or detailed explanation, but are properly referenced if the reader wishes to study their background. Therefore, it is assumed the reader has a fundamental understanding of basic hydrology and hydraulics. A working knowledge of the Rational Equation (Chapter 3 – *Determination of Stormwater Runoff*) and open channel hydraulics (Chapter 6 – *Open Channel Flow Design*) is particularly helpful.

Summary of Critical Design Criteria

The summary below outlines some of the most critical design criteria essential to design engineers for proper drainage design of streets, inlets, and storm sewers according to City of Rogers' requirements. The information below contains exact numerical criteria as well as general guidelines that must be adhered to during the design process. This section is meant to be a summary of critical design criteria for this section; however, the engineer is responsible for all information in this chapter. It should be noted that any design engineer who is not familiar with Rogers' Drainage Criteria Manual and its accepted design techniques and methodology should review the entirety of this chapter. If additional specific information is required, it will be necessary to review the appropriate section as needed.

1.0 STREET DRAINAGE

Street Class	Street Width	Depth at Curb	Maximum Encroachment	Maximum Width of Gutter Flow (Typical Section)
Minor Class I	30-ft	No overtopping	Half of roadway width (F.O.C. to F.O.C.) to remain clear.	≤ 7.25-ft
Collector Class II	40-ft	No overtopping	Half of roadway width (F.O.C. to F.O.C.) to remain clear.	≤ 9.75-ft
Minor Arterial Class III	52-ft	No overtopping	Half of roadway width (F.O.C. to F.O.C.) to remain clear.	≤ 12.75-ft
Major Arterial Class IV	64-ft	No overtopping	Half of roadway width (F.O.C. to F.O.C.) to remain clear.	≤ 15.75-ft
Boulevard Class IV	68-ft	No overtopping	Half of roadway width (F.O.C. to F.O.C.) to remain clear in each direction.	≤ 13.75-ft

Stormwater Flow – Pavement Encroachment and Curb Depth Standards for the Minor Storm, 10-yr Return Frequency

- Refer to [Section 1.2](#) for more detailed information/explanation/derivation
- Refer to [Table ST-1](#) for more detailed information/explanation
- Refer to [Section 1.3.1](#) for allowable gutter flow.

STORM SEWER SYSTEM DESIGN

Stormwater Flow – Curb Depth and Street Inundation Standards for the Major Storm, 100-yr Return Frequency.

- Refer to [Section 1.2](#) for more detailed information/explanation
- Refer to [Table ST-2](#) for more detailed information/explanation

Street Class	Maximum Depth and Inundated Area
Minor & Collector	<ul style="list-style-type: none"> - Residential dwellings and public, commercial, and industrial buildings \geq 12-inches above the 100-yr at the ground line or lowest water entry of the building - Depth of water at curb \leq 18-inches. - Min. F.F.E. \geq 1-foot above top of curb.
Minor Arterial Major Arterial Boulevard	<ul style="list-style-type: none"> - Residential dwellings and public, commercial, and industrial buildings \geq 12-inches above the 100-yr at the ground line or lowest water entry of the building - The depth of water shall not exceed the street curb to allow operation of emergency vehicles. Depth of water at curb \leq 12-inches. - Min. F.F.E. \geq 1-foot above top of curb.

Allowable Stormwater Flow Through Cross-Street/Intersection

- Refer to [Section 1.2](#) for more detailed information/explanation
- Refer to [Table ST-3](#) for more detailed information/explanation

Street Class	Minor (10-yr) Storm Flow Depth	Major (100-yr) Storm Flow Depth
Local	\leq 6-inches in cross pan	\leq 12-inches above gutter flow line
Collector	Where cross pans allow \leq 4-inches in cross pan	\leq 12-inches above gutter flow line
Minor Arterial	None	No cross flow through intersection or across a street. Max depth upstream gutter \leq 12-inches
Major Arterial	None	No cross flow through intersection or across a street. Max depth upstream gutter \leq 12-inches
Boulevard	None	No cross flow through intersection or across a street. Max depth upstream gutter \leq 12-inches

DRAINAGE CRITERIA MANUAL

Physical Constraints for Curb and Gutter

- Minimum Longitudinal Grade = 0.005-ft/ft
- Minimum Cross Slope = 0.02-ft/ft
- Maximum Velocity of Curb Flow \leq 7-ft/sec at \leq 3-inches of depth
- Typical Manning's n-value = 0.015 (see pg. ST-13)
- Refer to [Section 1.3.2](#) for more detailed information/explanation

Physical Constraints for Roadside Swales

- Maximum 10-year flow velocity \leq 4-ft/sec
- Maximum Longitudinal Grade of a Grass-lined Swale \leq 0.02-ft/ft. Use grade control checks if adjacent street is steeper to limit the swale's flow.
- Maximum Flow Depth \leq 1.0-ft
- Maximum Side Slope \leq 3H:1V
- Refer to [Section 1.3.3](#) for more detailed information/explanation

2.0 STORM DRAIN INLETS

Inlet Types and Applicable Settings

- Refer to [Section 2.1](#) for more detailed information/explanation
- See [Table ST-5](#) for more detailed information/explanation

Inlet Type	Applicable Settings	Advantages	Disadvantages
Grate	Sumps and continuous grades (must be bicycle safe)	Perform well over wide range of grades	Can become clogged, lose some capacity with increasing grade
Curb-opening	Sumps and continuous grades (but not steep grades)	Do not clog easily Bicycle safe	Lose capacity with increasing grade
Combination	Sumps and continuous grades (must be bicycle safe)	High capacity Do not clog easily	More expensive than grate or curb-opening acting alone
Slotted	Locations where sheet flow must be intercepted	Intercept flow over wide section	Susceptible to clogging

STORM SEWER SYSTEM DESIGN

Area Inlet	Sumps or a lower pond on a site where runoff can be efficiently collected	Do not clog easily Bicycle safe	Protrude above ground and are limited to certain locations (such as yards, etc.)
------------	---	------------------------------------	--

Physical Constraints for Storm Drain Inlets / Junction Boxes

- Refer to [Section 3.3.2](#) for more detailed information/explanation
- Inlets / junction boxes shall have 24" lids w/City of Rogers logo and fish. Rings and lids shall be heavy duty, traffic rated when in traffic areas or ROW
- Inlet curb-opening lengths shall be in 4-foot increments. The one exception shall be that curb inlets with a 5-foot interior diameter may have a 5-foot opening if they do not have extensions.
- Inlets / junction boxes shall be sized as shown in the following table (same as [Table ST-11](#)).
- Inlets / junction boxes shall be HL-93 traffic rated if in ROW or traffic areas

Inlet / Junction Box Sizing

Storm Sewer Pipe Diameter at Outlet End (inches)	Inlet / Junction Box Min. Interior Diameter / Width (feet)
18	4
21 to 42	5
48 to 54	6
60 and larger	To be approved by City
Multiple STS pipes entering structure	Provide 1-foot (min.) between each STS and 1-foot (min.) between the outside edge of the STS and interior wall of the inlet/junction box

Inlet Spacing

- Refer to [Section 3.3.2](#) for more detailed information/explanation
- Space inlets so as not to exceed the allowable encroachment widths as defined in [Table ST-1](#)
- Space inlets so that a carryover flow between 20- to 40-percent occurs at each inlet on grade
- Inlets / junction boxes shall be spaced at a maximum as shown in the following table (same as [Table ST-10](#)).

Inlet / Junction Box Spacing Based on Storm Sewer Pipe Size

DRAINAGE CRITERIA MANUAL

Vertical Dimension of Pipe (and equivalent Box Culvert Height) (inches)	Maximum Allowable Distance Between Inlet / Junction Boxes and/or Cleanout Points (feet)
18 to 36	400
42 and larger	500

Inlets Located in Sumps and “Flat” Grades

- Refer to [Section 2.3.5](#) for more detailed information/explanation
- Inlets located on grades $\leq 1.0\%$ and at sumps:
 - ...shall not have a grate inlet acting as the sole inlet.
 - ...shall have a minimum curb opening of 12-feet.
 - ...shall have positive drainage in some form provided to convey/collect any ponded water that could result from a 100% clogged inlet.

Inlet Clogging Factors

- Refer to [Section 2.3.6](#) for more detailed information/explanation
- Inlets in a Sump:
 - Single Grate Inlet – 50% reduction
 - Combination-Curb Inlet – 30% reduction
 - Single Curb-Opening Inlet – 20% reduction
 - Multiple-Unit Street Inlet – use clogging coefficient(s)/factor(s) and methodology as defined in [Table ST-8](#) in [Section 2.3.6](#)
- Inlets on Grade:
 - Single Grate Inlet – 25% reduction
 - Combination-Curb Inlet – 25% reduction

3.0 STORM SEWERS

Storm Sewer Pipe Shape

- Refer to [Section 3.3.1](#) for more detailed information/explanation
- Circular – preferred shape

STORM SEWER SYSTEM DESIGN

- Horizontal elliptical – must be hydraulically equivalent to the round pipe size
- Arch – must be hydraulically equivalent to the round pipe size
- Box

Storm Sewer Pipe Material

- Refer to [Section 3.3.1](#) for more detailed information/explanation
- Reinforced Concrete Pipe (RCP)
 - RCP shall be used in all street right-of-way areas and under all traffic areas (including parking lots, driveways, etc. that are outside of right-of-way).
 - RCP shall conform to:
 - Circular pipe - AASHTO M 170/ASTM C-76
 - Arch pipe - AASHTO M 206/ASTM C-506
 - Elliptical Pipe - AASHTO M 207/ASTM C507
 - All STS pipe having a diameter of 18-inches or greater shall be RCP.
 - Minimum 2-foot cover in traffic areas.
 - Minimum 1-foot cover in all other areas.
 - RCP must meet ASTM Class III specifications
 - Flared end sections must meet ASTM Class II or higher specifications
 - The joint seal shall be either cement mortar, three parts sand and one part cement, or cold applied performed plastic gaskets conforming to the latest applicable AASHTO designation.
- Corrugated Metal Pipe (CMP) [including Smooth Lined (SLCMP)]
 - CMP may not be used:
 - ...in City right-of-way
 - ...under traffic areas
 - ...in City drainage easements
 - ...to convey water through a development from properties upstream
 - ...on properties where drainage structures are maintained by a residential POA
 - All STS pipe having a diameter of 18-inches or greater shall be RCP.

DRAINAGE CRITERIA MANUAL

- CMP up to 18-inches can be used in areas outside of the right-of-way and outside of city drainage easements if it meets all other criteria herein.
- CMP shall conform to:
 - Galvanized Steel - AASHTO M218/ASTM A929; AASHTO M36/ASTM A760 and AASHTO Section 12/ASTM A796
 - Aluminized Steel Type 2 – AASHTO M274/ASTM A929; AASHTO M36/ASTM A760 and AASHTO Section 12/ASTM A796
 - Aluminum – AASHTO M197/ASTM B744; AASHTO M196/ASTM B745 and AASHTO Section 12/ASTM B790
- CMP shall have a minimum cover of 2-foot.
- Flared end sections shall be of the same material as the culvert pipe for a given installation, and shall be fabricated from steel sheets having a thickness of 0.064 inches or more.
- Coupling bands and other hardware for corrugated metal pipe shall conform to the latest applicable AASHTO designation and shall be made of the same base metal and coating as the pipe. Band widths shall be as specified in the latest applicable AASHTO designation.
-
- Corrugated Polyethylene Pipe (CPP) [including Smooth Lined (SLCPP)]
 - CPP may not be used:
 - ...in City right-of-way
 - ...under traffic areas
 - ...in City drainage easements
 - ...to convey water through a development from properties upstream
 - ...on properties where drainage structures are maintained by a residential POA
 - All STS pipe having a diameter of 18-inches or greater shall be RCP.
 - CPP up to 18-inches can be used in areas outside of the right-of-way and outside of city drainage easements if it meets all other criteria herein.
 - CPP shall conform to AASHTO M 294, Type S specification / ASTM F2648, ASTM D3350 and ASTM F2306.

STORM SEWER SYSTEM DESIGN

- CPP shall have a minimum cover of 2-foot.

Storm Sewer Pipe Physical and Operational Constraints

- Refer to [Section 3.3.1](#) for more detailed information/explanation.
- All STS pipe having a diameter \geq 18-inches must be RCP.
- Minimum Pipe Size = 18-inches
- Minimum Pipe Slope = 0.004-ft/ft
- Design storm frequency = 10-year design storm
- Maximum design flow capacity at Design Storm Frequency (10-yr) = 80% full flow capacity
- 2 feet from ground surface (gutterline) to Hydraulic Grade Line (HGL).
- Design shall manage 100-year storm runoff so that it is contained within the R.O.W. or a drainage easement and adjacent properties are protected from damage.
- Minimum Flow Velocity flowing under Design Storm (10-yr) Capacity = 3.0-ft/sec
- Maximum Flow Velocity flowing under any design storm and capacity = 12-ft/sec
- Maximum Pipe Cover shall be per Manufacturer's recommendation or ARDOT standards, whichever is more restrictive.
- Assume full flow conditions for discharge into an existing storm sewer system or ditch for which no design information exists.

1.0 STREET DRAINAGE

1.1 Street Function and Classification

The primary function of a street or roadway is to provide for the safe passage of vehicular traffic at a specified level of service. If stormwater collection and conveyance systems are not designed properly, this primary function can be impaired when streets flood due to surcharge in storm sewers and street encroachment. To make sure this does not happen, streets are classified for drainage purposes based on their traffic volume, parking practices, and other criteria (Wright-McLaughlin Engineers 1969). The five street classifications for the City of Rogers are:

- Minor: low-speed traffic for residential or industrial area access.
- Collector: low/moderate-speed traffic providing service between local streets and arterials.
- Minor Arterial: moderate/high-speed traffic moving through urban areas.
- Major Arterial: moderate/high-speed traffic moving through urban areas.
- Boulevard: moderate/high-speed traffic moving through urban areas.

For drainage design, the classification shown on the Rogers Master Street Plan shall be used unless a higher standard is deemed appropriate by the Engineer of Record or City. Refer to *Chapter 14 – Development; Article II – Design Criteria and Construction Specifications for Division, Development and Improvement of Land; Division 2 – Construction; Section 14-44* in the City of Rogers’ “Code of Ordinances” for layout design standards and criteria for the street classifications mentioned above (<http://library.municode.com>).

Streets serve another important function other than traffic flow. They contain the first component in the urban stormwater collection and conveyance system. That component is the street gutter or adjacent swale, which collects excess stormwater from the street and adjacent areas and conveys it to a stormwater inlet. Proper street drainage is essential to:

- Maintain the street’s level-of-service.
- Reduce skid potential.
- Minimize the potential for cars to hydroplane.
- Maintain good visibility for drivers by reducing splash and spray.
- Minimize inconvenience/danger to pedestrians during storm events (FHWA 1984).

1.2 Design Considerations

Stormwater which flows in a street will flow in the gutters of the street until it reaches an overflow point or some other outlet/inlet. During its travel time the top width (or spread) of the stormwater flowing in the

gutter widens as more stormwater is collected. Certain design considerations must be taken into account in order to meet the drainage objectives of a street to handle the stormwater flowing in the gutter. The primary design objective is to maintain permissible values of spread (encroachment) for minor storm (10-yr frequency) events. If the width and depth of the flow becomes great enough, the street loses its effectiveness as a traffic-carrier and travel becomes hazardous. Based on this, the City has established encroachment standards for the minor storm event. These encroachment standards are shown in [Table ST-1](#).

Table ST-1 — Pavement Encroachment and Curb Depth Standards for the Minor Storm, 10-yr Return Frequency

Street Class		Depth at Curb	Maximum Encroachment	Example Based on Given Street Width (Normal Typical Section)
Minor	No curb overtopping	Spread of water flowing gutter shall be limited so that half of roadway width (F.O.C. to F.O.C.) remains clear.	- Street Width (F.O.C. to F.O.C.) = 29-ft - Required Clear Lane = $29\text{-ft}/2 = 14.5\text{-ft}$ - Therefore: Street flow in each gutter $\leq (29\text{'-}14.5\text{'})/2 = \mathbf{7.25\text{-ft}}$	
Collector	No curb overtopping	Spread of water flowing gutter shall be limited so that half of roadway width (F.O.C. to F.O.C.) remains clear.	- Street Width (F.O.C. to F.O.C.) = 39-ft - Required Clear Lane = $39\text{-ft}/2 = 19.5\text{-ft}$ - Therefore: Street flow in each gutter $\leq (39\text{'-}19.5\text{'})/2 = \mathbf{9.75\text{-ft}}$	
Minor Arterial	No curb overtopping	Spread of water flowing gutter shall be limited so that half of roadway width (F.O.C. to F.O.C.) remains clear.	- Street Width (F.O.C. to F.O.C.) = 51-ft - Required Clear Lane = $51\text{-ft}/2 = 25.5\text{-ft}$ - Therefore: Street flow in each gutter $\leq (51\text{'-}25.5\text{'})/2 = \mathbf{12.75\text{-ft}}$	
Major Arterial	No curb overtopping	Spread of water flowing gutter shall be limited so that half of roadway width (F.O.C. to F.O.C.) remains clear.	- Street Width (F.O.C. to F.O.C.) = 63-ft - Required Clear Lane = $63\text{-ft}/2 = 31.5\text{-ft}$ - Therefore: Street flow in each gutter $\leq (63\text{'-}31.5\text{'})/2 = \mathbf{15.75\text{-ft}}$	
Boulevard	No curb overtopping	Spread of water flowing gutter shall be limited so that half of roadway width (F.O.C. to F.O.C.) remains clear each direction.	- Street Width (F.O.C. to F.O.C.) Each Direction = 27-ft ; - Required Clear Lane = $27.5\text{'}/2 = 13.5\text{-ft}$ - Therefore: Street flow in each gutter $\leq (27.5\text{'})/2 = \mathbf{13.5\text{-ft}}$	

Additional design objectives are required for major storm (100-yr frequency) events and resulting gutter flows and street cross flows. The main factor to be considered when evaluating the major storm event is to determine the potential for flooding and public safety. Cross-street/intersection flows also need to be regulated for traffic flow and public safety. The City has established street inundation standards during the major storm event and allowable cross-street/intersection flow standards. These standards are shown in [Table ST-2](#) and [Table ST-3](#).

Table ST-2 — Street Inundation Standards for the Major Storm, 100-yr Return Frequency

Street Classification	Maximum Depth and Inundated Area
Minor And Collector	Residential dwellings and public, commercial, buildings shall be no less than 12-inches above the ground line at the ground line or lowest water entry of the building. The depth of water over the gutter flow line shall not exceed 18-inches. Minimum finished floor elevation (F.F.E) shall be 1-foot above top of curb.
Minor Arterial Major Arterial and Boulevard	Residential dwellings and public, commercial, buildings shall be no less than 12-inches above the ground line at the ground line or lowest water entry of the building. The depth of water shall not exceed the street operation of emergency vehicles. The depth of water over the gutter flow line shall not exceed 12-inches. Minimum finished floor elevation (F.F.E) shall be 1-foot above top of curb.

Table ST-3 — Allowable Cross-Street/Intersection Flows

Street Classification	Minor (10-yr) Storm	Major (100-yr) Storm Flow
Local	6-inches of depth in cross pan.	12-inches of depth above gutter flow line.
Collector	Where cross pans are used, the depth of flow shall not exceed 4-inches.	12-inches of depth above gutter flow line.
Minor Arterial	None.	No cross flow through intersection. Maximum depth at upstream road edge of 12-inches.
Major Arterial	None.	No cross flow through intersection. Maximum depth at upstream road edge of 12-inches.
Boulevard	None.	No cross flow through intersection. Maximum depth at upstream road edge of 12-inches.

1.3 Hydraulic Evaluation of Street Gutters and Swales

Hydraulic computations are performed to determine the capacity of roadside swales and street gutters and the encroachment of stormwater onto the street. The design discharge is usually determined using the Rational Method (covered later in this chapter). Stormwater runoff ends up in swales, roadside ditches and street gutters.

1.3.1 Evaluation Procedures

The hydraulic evaluation of street capacity includes the following steps:

STORM SEWER SYSTEM DESIGN

1. Calculate the theoretical street gutter flow capacity to convey the minor storm based upon the allowable **spread** defined in [Table ST-1](#).
2. Calculate the theoretical street gutter flow capacity to convey the minor storm based upon the allowable **depth** defined [Table ST-1](#).
3. Calculate the allowable street gutter flow capacity by multiplying the theoretical capacity (calculated in number 2) by a reduction factor (see [Figure ST-3](#)). This reduction factor is used for safety considerations. The lesser of the capacities calculated in step 1 and this step is the allowable street gutter capacity.
4. Calculate the theoretical major storm conveyance capacity based upon the road inundation criteria in [Table ST-2](#). Reduce the major storm capacity by a reduction factor to determine the allowable storm conveyance capacity. (see [Figure ST-3](#))

1.3.2 Curb and Gutter

1.3.2.1 Physical Constraints for Longitudinal Slope and Cross Slope

Streets are characterized with two different slope components: longitudinal slope and cross slope. A gutter's longitudinal slope will match the street's longitudinal slope. The hydraulic capacity of a gutter increases as the longitudinal slope increases. To ensure cleaning velocities at very low flows, the gutter shall have a minimum slope of 0.005 feet per foot (0.5%). The allowable flow capacity of the gutter on steep slopes ($\geq 6\%$) is limited to provide for public safety and as such the maximum velocity of curb flow shall be ≤ 7 -feet per second and limited to 3-inches of depth.

The cross slope of a street represents the slope from the street crown to the gutter section. The City requires a minimum cross slope of 2% for pavement drainage. Typically, a gutter's cross slope matches the street's cross slope. However, composite gutter sections are often used with gutter cross slopes being steeper than street cross slopes to increase the hydraulic capacity of the gutter.

1.3.2.2 Gutters With Uniform Cross Slopes (i.e., Where Gutter Cross Slope = Street Cross Slope)

Gutter flow is assumed to be uniform for design purposes; therefore Manning's equation is appropriate with a slight modification to account for the effects of a small hydraulic radius. For a triangular cross section ([Figure ST-1](#)), the Manning formula for gutter flow is written as:

$$Q = \frac{0.56}{n} * S_x^{5/3} * S_L^{1/2} * T^{8/3} \quad \text{(Equation ST-1)}$$

in which:

Q = calculated flow rate for the street (cfs)

n = Manning's roughness coefficient, (typically = 0.013). Refer to [Table ST-4](#) for other gutter and pavement types

S_x = street cross slope (ft/ft)

DRAINAGE CRITERIA MANUAL

S_L = street longitudinal slope (ft/ft)

T = top width of flow spread (ft)

Figure ST-1 — Typical Gutter Section – Constant Cross Slope (VDOT Drainage Manual 2010)

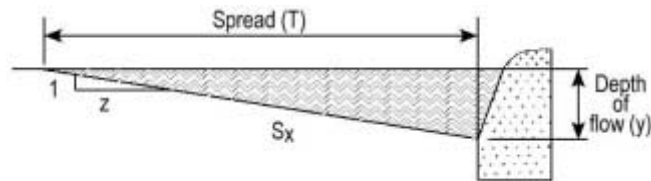

Table ST-4 — Manning's n Values For Street and Pavement Gutters (FHWA – HDS-3 1961)

Type of Gutter or Pavements	Manning's n
Concrete gutter, troweled finished	0.012
Asphalt pavement:	
Smooth texture	0.013
Rough texture	0.016
Concrete gutter with asphalt pavement:	
Smooth	0.013
Rough	0.015
Concrete pavement:	
Float finish	0.014
Broom finish	0.016
For gutters with small slopes, where sediment may accumulate, increase above values of n by	0.002

The depth of flow, y , at the curb can be found using:

$$y = T * S_x \tag{Equation ST-2}$$

Note that the flow depth must be less than the curb height during the minor storm based on [Table ST-1](#). Manning's equation can be written in terms of the flow depth, as:

$$Q = \frac{0.56}{n} * S_L^{1/2} * y^{8/3} \tag{Equation ST-3}$$

The cross-sectional flow area, A , can be expressed as:

$$A = (1/2) * S_x * T^2 \tag{Equation ST-4}$$

The gutter velocity at peak capacity may be found from the continuity equation ($V = Q/A$).

1.3.2.3 Gutters With Composite Cross Slopes (i.e., Where Gutter Cross Slope ≠ Street Cross Slope)

Gutters with composite cross slopes ([Figure ST-2](#)) can be used to increase the gutter capacity.

Figure ST-2 — Typical Gutter Section – Composite Cross Slope (VDOT Drainage Manual 2010)

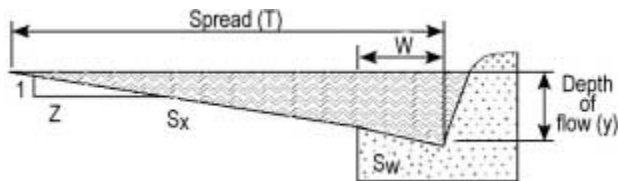

For a composite gutter section:

$$Q = Q_w + Q_s \tag{Equation ST-5}$$

in which:

Q_w = flow rate in the depressed section of the gutter (cfs)

Q_s = discharge in the section that is above the depressed section (cfs)

The Federal Highway Administration's [HEC-22](#) (2001) provides the following equations for obtaining the flow rate in gutters with composite cross slopes. The theoretical flow rate, Q , is:

$$Q = \frac{Q_s}{1 - E_o} \quad \text{(Equation ST-6)}$$

in which:

$$E_o = \frac{1}{1 + \frac{S_w/S_x}{\left[1 + \frac{S_w/S_x}{(T/W) - 1}\right]^{8/3}} - 1} \quad \text{(Equation ST-7)}$$

in which S_w is the gutter cross slope (ft/ft), and,

$$S_w = S_x + \frac{a}{W} \quad \text{(Equation ST-8)}$$

in which a is the gutter depression (feet) and W is width of the gutter (ft).

[Figure ST-2](#) depicts all geometric variables. From the geometry, it can be shown that:

$$y = a + T * S_x \quad \text{(Equation ST-9)}$$

and,

$$A = \frac{1}{2} * S_x * T^2 + \frac{1}{2} * a * W \quad \text{(Equation ST-10)}$$

in which y is the flow depth (at the curb) and A is the flow area.

1.3.2.4 Allowable Gutter Hydraulic Capacity

As stormwater flows along streets, it encounters obstructions and other limiting street conditions that decrease the gutter's hydraulic capacity. These conditions include street overlays, parked vehicles, debris and hail accumulation, and deteriorated pavement. Due to the negative impact these street conditions have on the stormwater flow in the gutter, a reduction factor is applied to the theoretical gutter capacity. The reduction factor also is used to minimize damaging gutter flow velocities and depths. Utilizing the reduction factor, the allowable gutter hydraulic capacity is determined as the lesser of:

$$Q_A = Q_T \quad \text{(Equation ST-11)}$$

or

$$Q_A = R * Q_F \quad \text{(Equation ST-12)}$$

in which Q_A = allowable street hydraulic capacity, Q_T = street hydraulic capacity limited by the maximum water spread, R = reduction factor (see [Figure ST-3](#)), and Q_F = gutter capacity when flow depth equals allowable depth.

There are two sets of reduction factors developed for the City of Rogers based on the reduction factor equation(s) discussed in *Urban Hydrology and Hydraulics Design* (Guo 2000b). One is for the minor event, and another is for the major event. [Figure ST-3](#) shows that the reduction factor remains constant for a street slope <1.5%, and then decreases as the street slope increases.

It is important for street drainage designs that the allowable street hydraulic capacity be used instead of the calculated gutter-full capacity. Thus, wherever the accumulated stormwater amount on the street is close to the allowable capacity, a street inlet shall be installed.

Figure ST-3 — Reduction Factor for Allowable Gutter Capacity

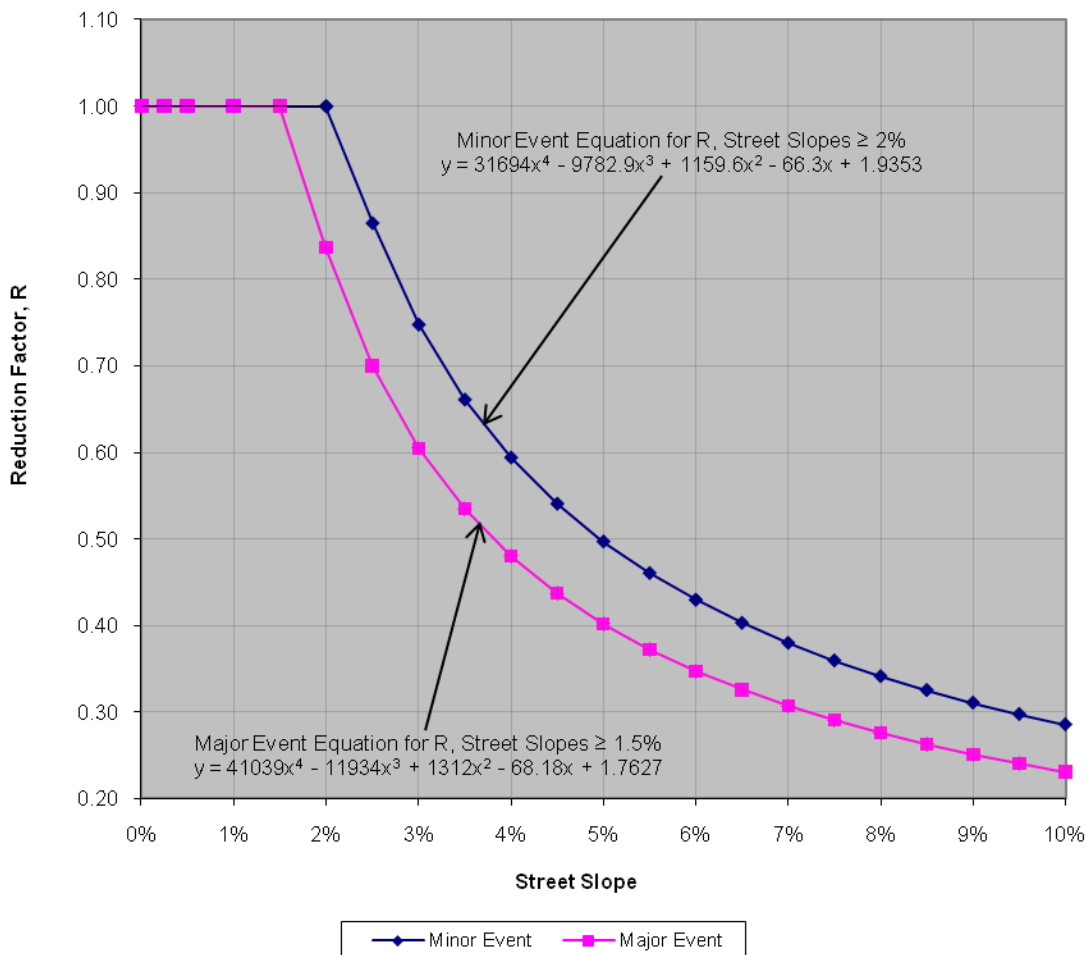

1.3.3 Swale Sections (V-Shaped With the Same or Different Side Slopes)

Swales are often used to convey runoff from pavement where curb and gutter sections are not used. It is very important that swale depths and side slopes be as shallow as possible for safety and maintenance

DRAINAGE CRITERIA MANUAL

reasons. Street-side swales serve as collectors of initial runoff and transport it to the nearest inlet or major drainageway. To be effective, they need to be limited to the velocity, depth, and cross-slope geometries considered acceptable. The following limitations shall apply to street-side swales:

- Maximum flow velocity ≤ 4 ft/sec for grass-lined swales for 10-year event.
- Longitudinal grade of a grass-lined swale $\leq 2\%$. Use grade control checks if adjacent street is steeper to limit the swale's flow.
- Maximum flow depth (d) ≤ 1.0 ft. for 10-year event.
- Maximum side slope of each side (S_{x1} and S_{x2}) $\leq 3H:1V$.*

* Note: Use of flatter side slopes is strongly recommended.

Swales generally have V-sections ([Figure ST-4](#)). [Equation ST-1](#) can be used to calculate the flow rate in a V-section (if the section has a constant Manning's n value) with an adjusted slope found using:

$$S_X = \frac{S_{x1} * S_{x2}}{S_{x1} + S_{x2}} \quad \text{(Equation ST-13)}$$

in which:

S_X = adjusted side slope (ft/ft)

S_{x1} = right side slope (ft/ft)

S_{x2} = left side slope (ft/ft)

[Figure ST-4](#) shows the geometric variables.

Figure ST-4 — Typical Street-Side Swale Sections—V-Shaped (UDFCD USDCM 2002)

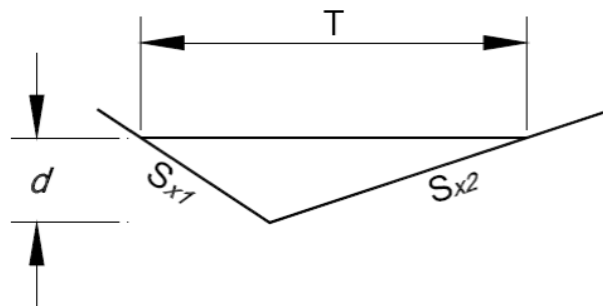

Note that the slope of swales is often different than the adjacent street. The hydraulic characteristics of the swale can therefore change from one location to another on a given swale. The flow depth and spread limitations of [Table ST-2](#) and [Table ST-3](#) are also valid for swales. There is no capacity reduction for safety considerations for roadside swales.

Manning's equation can be used to calculate flow characteristics.

$$Q = \frac{1.49}{n} * A * R^{2/3} * S_L^{1/2} \quad \text{(Equation ST-14)}$$

in which:

Q = flow rate (cfs)

n = Manning's roughness coefficient (see [Table ST-4](#))

A = flow area (ft²)

R = A/P (ft)

P = wetted perimeter (ft)

S_L = longitudinal slope (ft/ft)

2.0 STORM DRAIN INLETS

2.1 Inlet Functions, Types and Appropriate Applications

Once the design flow spread (encroachment) has been established for the minor storm, the placement of inlets can be determined. The primary function of stormwater inlets is to intercept excess surface runoff and deposit it in storm sewers, thereby reducing the possibility of surface flooding.

The location of storm drain inlets along a road is influenced by the roadway's geometry as well as adjacent land features. As a rule, inlets are placed at all low points in the gutter grade, median breaks, intersections, and at or near crosswalks. Along with adhering to the geometric controls outlined above, storm drain inlet spacing shall be such that the gutter spread under the design storm (10-yr frequency) conditions will not exceed the allowable encroachment for the type of street class under consideration. ([Table ST-1](#))

There are five major types of storm drain inlets: grate, curb opening, combination, slotted and area. [Figure ST-5](#) depicts the major types of inlets along with some associated geometric variables. [Table ST-5](#) provides general information on the appropriate application of the different inlet types along with basic advantages and disadvantages of each.

Figure ST-5 — Types of Storm Drain Inlets (FHWA – HEC-22 2001)

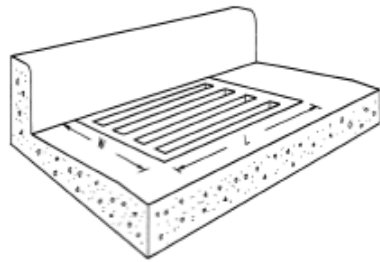

a. Grate

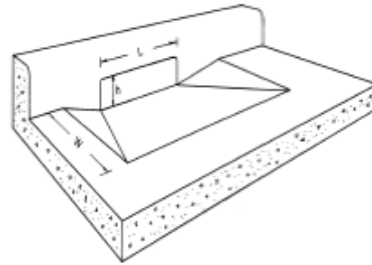

b. Curb-opening Inlet

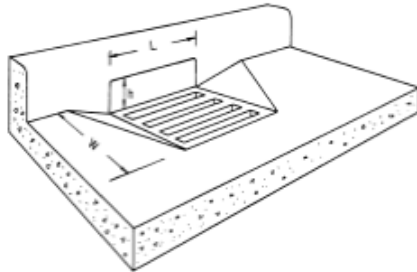

c. Combination Inlet

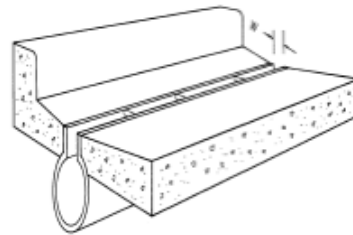

d. Slotted Drain Inlet

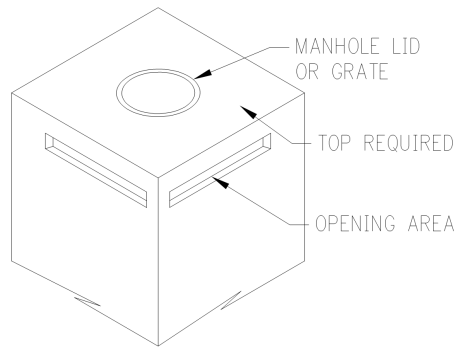

e. Area Inlet

Table ST-5 — Applicable Settings for Various Inlet Types

Inlet Type	Applicable Settings	Advantages	Disadvantages
Grate	Sumps and continuous grades (must be bicycle safe)	Perform well over wide range of grades	Can become clogged Lose some capacity with increasing grade
Curb opening	Sumps and continuous grades (but not steep grades)	Do not clog easily Bicycle safe	Lose capacity with increasing grade
Combination	Sumps and continuous grades (must be bicycle safe)	High capacity Do not clog easily	More expensive than grate or curb-opening acting alone
Slotted	Locations where sheet flow must be intercepted.	Intercept flow over wide section	Susceptible to clogging
Area Inlet	Sumps or a lower position on a site where runoff can be efficiently collected	Do not clog easily Bicycle safe	Protrude above ground and are limited to certain locations (such as yards, etc.)

2.2 Design Considerations

Stormwater inlet design takes two forms: inlet placement location and inlet hydraulic capacity. As previously mentioned, inlets must be placed in sumps to prevent ponding of excess stormwater. On streets with continuous grades, inlets are required periodically to keep the gutter flow from exceeding the encroachment limitations. In both cases, the size and type of inlets need to be designed based upon their hydraulic capacity.

Inlets placed on continuous grades rarely intercept all of the gutter flow during the minor (design) storm. The effectiveness of the inlet is expressed as an efficiency, E , which is defined as:

$$E = Q_i / Q \quad \text{(Equation ST-15)}$$

in which:

E = inlet efficiency

Q_i = intercepted flow rate (cfs)

Q = total gutter flow rate (cfs)

Bypass (or carryover) flow is not intercepted by the inlet. By definition,

$$Q_b = Q - Q_i \quad \text{(Equation ST-16)}$$

DRAINAGE CRITERIA MANUAL

in which:

Q_b = bypass (or carryover) flow rate (cfs)

The ability of an inlet to intercept flow (i.e., hydraulic capacity) on a continuous grade generally increases with increasing gutter flow, but the capture efficiency decreases. In other words, even though more stormwater is captured, a smaller percentage of the gutter flow is captured. In general, the inlet capacity depends upon the following factors:

- Inlet type and geometry (length, width, etc.).
- Flow rate (depth and spread of water).
- Cross (transverse) slope (of road and gutter).
- Longitudinal slope.

As a general rule, an effective way to achieve an economic design and spacing for storm drain inlets is to allow 20- to 40-percent of gutter flow reaching the inlet to carry over to the next inlet downstream, provided that water flowing in the gutter does not exceed the allowable encroachment.

Inlets in sumps operate as weirs for shallow pond depths, but eventually will operate as orifices as the depth increases. A transition region exists between weir flow and orifice flow, much like a culvert. Grate inlets and slotted inlets tend to clog with debris, especially in sump conditions, so calculations shall take that into account. Curb opening inlets tend to be more dependable in sumps for this reason.

2.3 Hydraulic Evaluation

The hydraulic capacity of an inlet is dependent on the type of inlet (grate, curb opening, combination, or slotted) and the location (on a continuous grade or in a sump). The methodology for determination of hydraulic capacity of the various inlet types is described in the following sections:

- a) grate inlets on a continuous grade ([Section 2.3.1](#))
- b) curb opening inlets on a continuous grade ([Section 2.3.2](#))
- c) combination inlets on a continuous grade ([Section 2.3.3](#))
- d) slotted inlets on a continuous grade ([Section 2.3.4](#))
- e) inlets located in sumps ([Section 2.3.5](#)).

2.3.1 Grate Inlets (On a Continuous Grade)

The capture efficiency of a grate inlet is highly dependent on the width and length of the grate and the velocity of gutter flow. Ideally, if the gutter velocity is low and the spread of water does not exceed the grate width, all of the flow will be captured by the grate inlet. However, the spread of water often exceeds the grate width and the flow velocity can be high. Thus, some water gets by the inlet and because of this the inlet efficiency must be determined in order to evaluate the impact the bypass gutter flow will have on the efficiency and encroachment at the next inlet downstream of the bypassed inlet.

In order to determine the efficiency of a grate inlet, gutter flow is divided into two parts: frontal flow and side flow. Frontal flow is defined as that portion of the flow within the width of the grate. The portion of the flow outside the grate width is called side flow. By using [Equation ST-1](#), the frontal flow can be evaluated and is expressed as:

$$Q_w = Q \left[1 - \left(1 - \left(\frac{W}{T} \right) \right)^2 \right]^{0.67} \quad \text{(Equation ST-17)}$$

in which:

Q_w = frontal discharge (flow within width W) (cfs)

Q = total gutter flow (cfs) found using [Equation ST-1](#)

W = width of grate (ft)

T = total spread of water in the gutter (ft)

It should be noted that the grate width is generally equal to the depressed section in a composite gutter section. By definition:

$$Q_s = Q - Q_w \quad \text{(Equation ST-18)}$$

in which:

Q_s = side discharge (i.e., flow outside the depressed gutter or grate) (cfs)

The ratio of the frontal flow intercepted by the inlet to total frontal flow, R_f , is expressed as:

$$R_f = Q_{wi} / Q_w = 1.0 - 0.09(V - V_o) \quad \text{for } V \geq V_o, \text{ otherwise } R_f = 1.0 \quad \text{(Equation ST-19)}$$

in which:

Q_{wi} = frontal flow intercepted by the inlet (cfs)

V = velocity of flow in the gutter (ft/sec)

V_o = splash-over velocity (ft/sec)

[Figure ST-6](#) provides a graphical solution to [Equation ST-19](#).

Figure ST-6 — Grate Inlet Frontal Flow Interception Efficiency

(FHWA – HEC-22 2009)

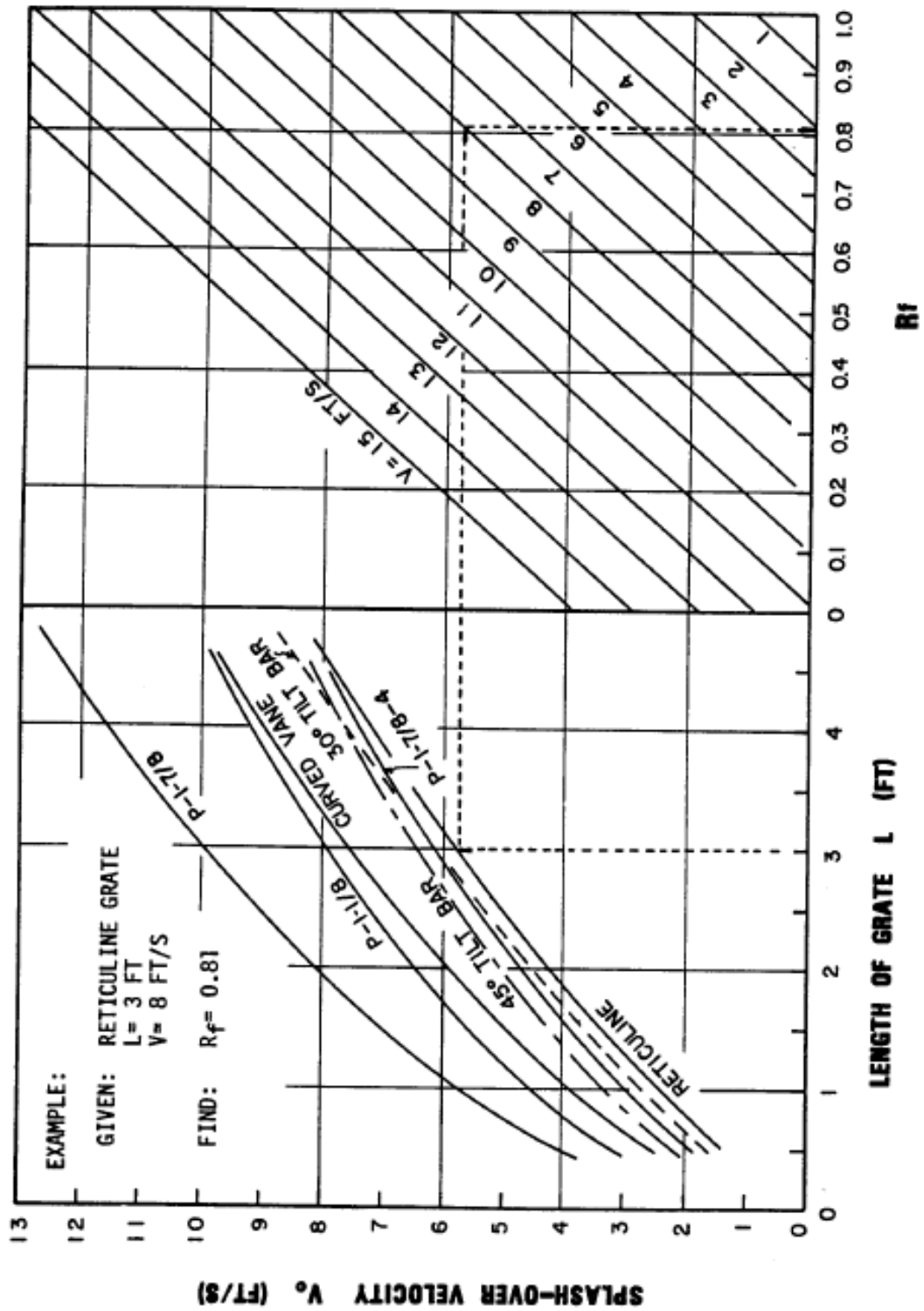

The splash-over velocity is defined as the minimum velocity causing some water to shoot over the grate. This velocity is a function of the grate length and type.

The splash-over velocity can be determined using the empirical formula (Guo 1999):

$$V_o = \alpha + \beta * L_e - \gamma * L_e^2 + \eta * L_e^3 \quad \text{(Equation ST-20)}$$

in which:

V_o = splash-over velocity (ft/sec)

L_e = effective unit length of grate inlet (ft)

$\alpha, \beta, \gamma, \eta$ = constants from [Table ST-6](#)

Table ST-6 — Splash Velocity Constants for Various Types of Inlet Grates
(UDFCD USDCM 2002)

Type of Grate	α	β	γ	η
Bar P-1-7/8	2.22	4.03	0.65	0.06
Bar P-1-1/8	1.76	3.12	0.45	0.03
Vane Grate	0.30	4.85	1.31	0.15
45-Degree Bar	0.99	2.64	0.36	0.03
Bar P-1-7/8-4	0.74	2.44	0.27	0.02
30-Degree Bar	0.51	2.34	0.20	0.01
Reticuline	0.28	2.28	0.18	0.01

The ratio of the side flow intercepted by the inlet to total side flow, R_s , is expressed as:

$$R_s = \frac{1}{1 + \frac{0.15 * V^{1.8}}{S_x * L^{2.3}}} \quad \text{(Equation ST-21)}$$

in which:

V = velocity of flow in the gutter (ft/sec)

S_x = street cross slope (ft/ft)

L = length of grate (ft)

[Figure ST-7](#) below provides a graphical solution to [Equation ST-21](#).

**Figure ST-7 — Grate Inlet Side Flow Interception Efficiency
(FHWA – HEC-22 2009)**

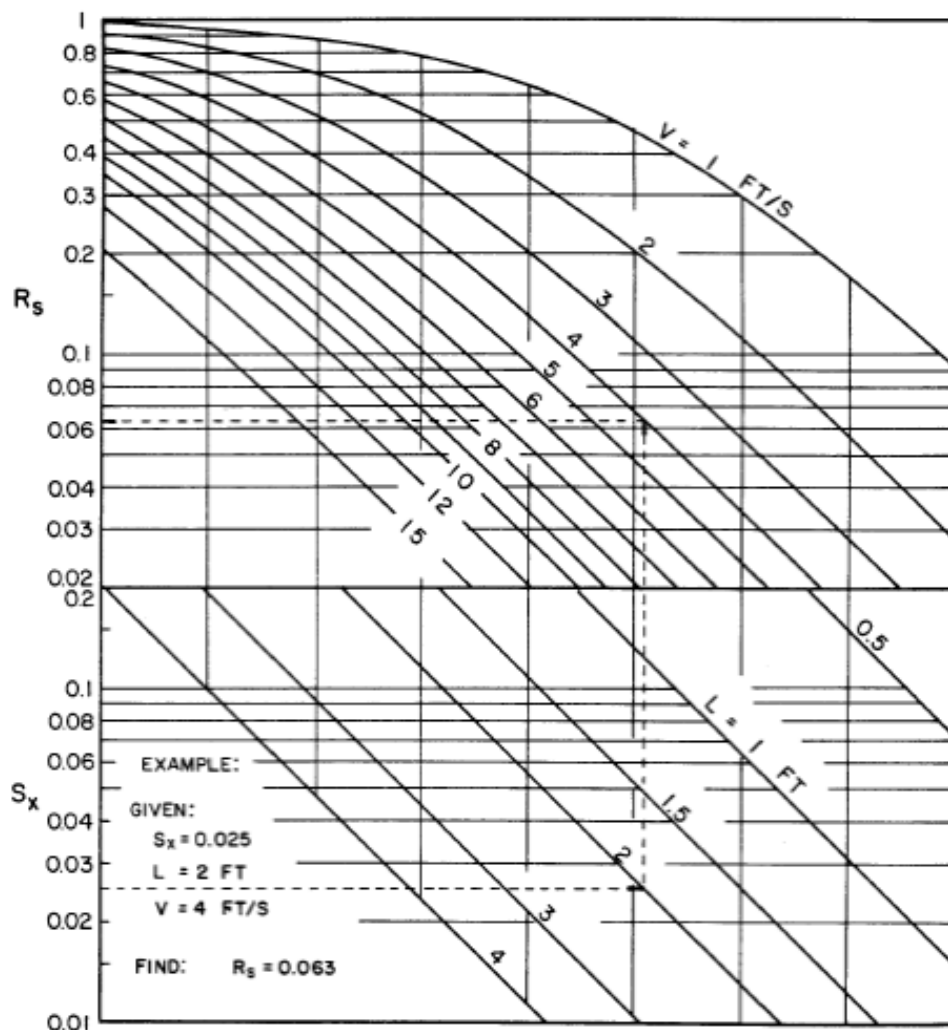

The capture efficiency, E , of the grate inlet may now be determined using:

$$E = R_f(Q_w/Q) + R_s(Q_s/Q) \quad \text{(Equation ST-22)}$$

2.3.2 Curb-Opening Inlets (On a Continuous Grade)

The capture efficiency of a curb-opening inlet is dependent on the length of the opening, the depth of flow at the curb, street cross slope and the longitudinal gutter slope. Ideally, if the curb opening is long, the flow rate is low, and the longitudinal gutter slope is small, all of the flow will be captured by the inlet. However, it is uneconomical to install a curb opening long enough to capture all of the flow for all situations and as a result some water gets by the inlet. Therefore, the inlet efficiency needs to be determined in order to evaluate the impact the bypass gutter flow will have on the efficiency and encroachment at the next inlet downstream of the bypassed inlet.

The efficiency, E , of a curb-opening inlet is calculated as:

$$E = 1 - \left[1 - \left(L/L_T\right)\right]^{1.8} \text{ for } L < L_T, \text{ otherwise } E = 1.0 \quad \text{(Equation ST-23)}$$

in which:

L = installed (or designed) curb-opening length (ft)

L_T = curb-opening length required to capture 100% of gutter flow (ft)

Design curb-opening length shall be in 4-foot increments.

[Figure ST-8](#) below provides a graphical solution to [Equation ST-23](#) once L_T is known.

Figure ST-8 — Curb-Opening and Slotted Drain Inlet Interception Efficiency (FHWA – HEC-22 2009)

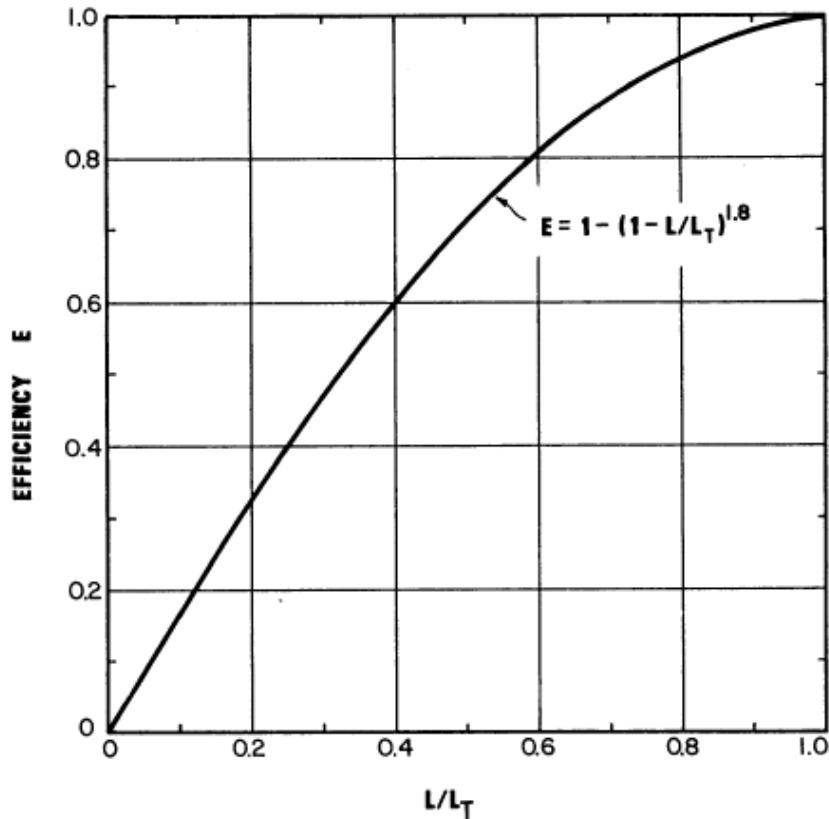

Besides at low points, inlets located on streets of less than one-percent (1%) grade, shall be considered and evaluated as inlets in sumps based on the procedures outlined in [Section 2.3.5](#).

2.3.2.1 Curb-Opening Inlet – Not Depressed

In the case of a curb-opening inlet that is not depressed, the depth of flow at the upstream end of the opening is the depth of flow in the gutter. In streets where grades are greater than one-percent (1%), the velocities are high and the depths of flow are usually small, which allows for little time to develop cross flow into a curb opening. Therefore, curb-opening inlets that are not depressed shall only be used on streets where the longitudinal grade is one-percent (1%) or less.

For a curb-opening inlet that is not depressed,

$$L_T = 0.6 * Q^{0.42} * S_L^{0.3} * \left(\frac{1}{n * S_X} \right)^{0.6} \tag{Equation ST-24}$$

in which:

Q = gutter flow (cfs)

S_L = longitudinal street slope (ft/ft)

S_X = street cross slope (ft/ft)

n = Manning’s roughness coefficient

2.3.2.2 Curb-Opening Inlet – Depressed

Depressing the gutter at a curb-opening inlet below the normal level of the gutter increases the cross-flow toward the opening, thereby increasing the inlet capacity. Also, the downstream transition out of the depression causes backwater which further increases the amount of water captured. Depressed inlets shall be used on continuous longitudinal grades that exceed one-percent (1%) except that their use in traffic lanes shall be approved by the City.

For a depressed curb-opening inlet,

$$L_T = 0.6 * Q^{0.42} * S_L^{0.3} * \left(\frac{1}{n * S_e} \right)^{0.6} \tag{Equation ST-25}$$

The equivalent cross slope, S_e , can be determined from

$$S_e = S_X + \frac{a}{W} * E_o \tag{Equation ST-26}$$

in which a = gutter depression and W = depressed gutter section as shown in [Figure ST-9](#). For a curb-opening inlet, a = 4.5-inches and W = 18-inches. The ratio of the flow in the depressed section to total gutter flow, E_o , can be calculated from [Equation ST-7](#).

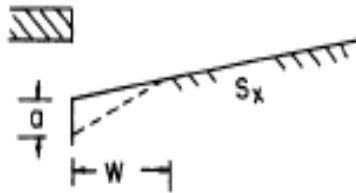
Figure ST-9 — Depressed Gutter Section (FHWA – HEC-22 2009)

2.3.3 Combination Inlets (On a Continuous Grade)

Combination inlets take advantage of the debris removal capabilities of a curb-opening inlet and the capture efficiency of a grate inlet. Interception capacity is computed by neglecting the curb opening if the grate and curb opening are side-by-side and of approximately the same length. A desirable configuration is to have all or part of the curb-opening inlet lie upstream from the grate, allowing the curb opening to intercept debris which might otherwise clog the grate and also provide additional capacity. A combination inlet with a curb opening upstream of the grate has an interception capacity equal to the sum of the two inlets, except that the frontal flow and thus the interception capacity of the grate is reduced by the amount of gutter flow intercepted by the curb opening. The appropriate equations have already been presented in [Section 2.3.1](#) and [Section 2.3.2](#).

2.3.4 Slotted Inlets (On a Continuous Grade)

Slotted inlets can generally be used to intercept sheet flow that is crossing the pavement in an undesirable location. Unlike grate inlets, they have the advantage of intercepting flow over a wide section. They do not interfere with traffic operations and can be used on both curbed and uncurbed sections. Like grate inlets, they are susceptible to clogging.

Slotted inlets function like a side-flow weir, much like curb-opening inlets. The FHWA [HEC-22](#) (2001) suggests the hydraulic capacity of slotted inlets closely corresponds to curb-opening inlets if the slot openings are equal to or greater than 1.75-inches. Therefore, the equations developed for curb-opening inlets ([Equation ST-23](#) through [Equation ST-26](#)) are appropriate for slotted inlets with openings ≥ 1.75 -inches. All slot inlets designed for use in the City of Rogers shall have slot openings ≥ 1.75 -inches.

2.3.5 Inlets Located in Sumps

All of the stormwater excess that enters a sump (i.e., a depression or low point in grade) must pass through an inlet to enter the stormwater conveyance system. If the stormwater is laden with debris, the inlet is susceptible to clogging and ponding could result. Therefore, the capacity of inlets in sumps must account for this clogging potential. Flanking inlets may be used on the upstream side of the sump just far enough away that before encroachment and ponding depth issues could begin the backwater built up due to the clog would be collected by the flanking inlets. At the very most the difference between the throat flowlines of the flanking inlet and sump inlet shall not be more than one-tenth of a foot (0.10-foot) less than the curb height. Grate inlets acting alone as the sole inlet in a sump shall not be allowed. Curb-

DRAINAGE CRITERIA MANUAL

opening inlets or combination inlets are to be used to capture stormwater runoff collecting in sumps. The minimum curb opening for inlets in sumps is 12-feet in street right-of-way or public access.

Positive drainage shall be provided at all sump inlets, so that if the sump inlet becomes 100% clogged there will be a way for stormwater to be conveyed away from the area and prevent encroaching and ponding depth noncompliance in the gutter section. Roadside swales shall be designed and placed in such a way that when the depth of stormwater at the curb exceeds the curb height, water will drain away from the road and be collected and conveyed in the swale.

Furthermore sumps or concentrated low points on a site can occur in areas isolated from curbed and guttered pavements and the information provided in this section can be used to analyze the collection of stormwater runoff at these locations. The type of inlet usually reserved to collect stormwater runoff in areas as described are called area inlets. Area inlets act as curb-opening inlets, but typically have curb openings on more than one side. Area inlets can also be grated inlets, like in the application of a grated inlet in a low point in the middle of a parking lot.

As previously mentioned, inlets in sumps function like weirs for shallow depths, but as the depth of stormwater increases, they begin to function like an orifice. The transition from weir flow to orifice flow takes place over a relatively small range of depth that is not well defined. The FHWA provides guidance on the transition region based on significant testing.

The hydraulic capacity of grate, curb-opening, and slotted inlets operating as weirs is expressed as:

$$Q_i = C_w * L_w * d^{1.5} \quad \text{(Equation ST-27)}$$

in which:

Q_i = inlet capacity (cfs)

C_w = weir discharge coefficient

L_w = weir length (ft)

d = flow depth (ft)

Values for C_w and L_w are presented in [Table ST-7](#) for various inlet types. (Note that the expressions given for curb-opening inlets without depression shall be used for depressed curb-opening inlets if $L > 12$ feet.)

The hydraulic capacity of grate, curb-opening, and slotted inlets operating as orifices is expressed as:

$$Q_i = C_o * A_o * (2 * g * d)^{0.5} \quad \text{(Equation ST-28)}$$

in which:

Q_i = inlet capacity (cfs)

C_o = orifice discharge coefficient

A_o = orifice area (ft²)

d = characteristic depth (ft) as defined in [Table ST-7](#)

$g = 32.2$ ft/sec²

Values for C_o and A_o are presented in [Table ST-7](#) for different types of inlets.

Combination inlets are commonly used in sumps. The hydraulic capacity of combination inlets in sumps depends on the type of flow and the relative lengths of the curb opening and grate. For weir flow, the capacity of a combination inlet (grate length equal to the curb opening length) is equal to the capacity of the grate portion only. This is because the curb opening does not add any length to the weir equation ([Equation ST-27](#)). If the curb opening is longer than the grate, the capacity of the additional curb length shall be added to the grate capacity. For orifice flow, the capacity of the curb opening shall be added to the capacity of the grate.

**Table ST-7 — Sag Inlet Discharge Variables and Coefficients
(Modified From Akan and Houghtalen 2002)**

Weir Flow				
Inlet Type	C_w	L_w 1	Weir Equation	Definitions of Terms
Grate Inlet	3.0	$L + 2d$	$d < 1.79(h)$	L = Length of grate W = Width of grate d = Depth of water over grate A_o = Clear opening area
Curb Opening Inlet	3.0	L	$d < h$	L = Length of curb opening h = Height of curb opening $d = d_i - (h / 2)$ d_i = Depth of water at curb
Depressed Opening	2.3	$L + 1.5d$	$d < (h)$	W = Lateral width of depressed opening a = Depth of curb depression
Slotted Inlet	2.4	L	$d < 0.5h$	L = Length of slot d = Depth at curb

1) The weir length shall be reduced where clogging is expected.
 2) Ratio of clear opening area to total area is 0.8 for P-1-7/8 grates, 0.6 for P-1-1/8 grates. Curved vane and tilt bar grates are exceptions. Provide actual value based on manufacturer's specifications.
 3) If $L > 12$ ft, use the expressions for curb opening inlets.

Orifice Flow				
Inlet Type	C_o	A_o 4	Orifice Equation	Definition of Terms

Grate Inlet	0.6	Clear opening area	$d > 1.79$	$d =$ Depth of water over
Curb Opening Inlet (depressed or undepressed horizontal throat ⁶⁾)	0.6	$(h)(L)$	$d_i > 1$	$d = d_i - (h / 2)$ $d_i =$ Depth of water at $h =$ Height of curb opening
Slotted Inlet	0.8	$(L)(W)$	$d > 0.4$	$L =$ Length of slot $W =$ Width of slot $d =$ Depth of water over

- 4) The orifice area shall be reduced where clogging is expected.
- 5) The ratio of clear opening area to total area is 0.8 for P- and 0.6 for P-1-1/8 grates. Curved vane and tilt bar grates shall provide actual value based on manufacturer's specifications.
- 6) See [Figure ST-10](#) for curb opening throat type to be used in design.

Figure ST-10 — Curb Opening Inlet Throat Type for Use in Design (FHWA – HEC 22 2009)

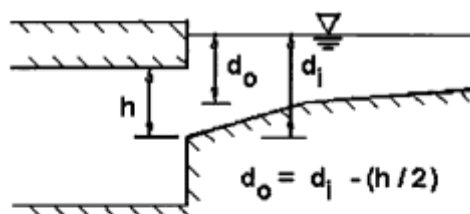

a. Horizontal Throat

2.3.6 Inlet Clogging

Inlets are subject to clogging when debris laden runoff is collected during the first-flush runoff volume during a storm event. Clogging factors (as a percent) shall be applied to the design lengths and or/areas calculated for the stormwater inlet in order to take into account the effects of clogging on each inlet type. A 50% clogging factor shall be used in the design of a single grate inlet, 30% clogging factor for a single combination-curb inlet, and 20% clogging factor for a single curb-opening inlet or area inlet in a sump. A 25% clogging factor shall be used in the design of a single grate inlet or the grate portion of a combination inlet when these inlets are located on grade.

Often, it takes multiple units to collect the stormwater on the street. Since the amount of debris is largely associated with the first-flush volume in a storm event, the clogging factor applied to a multiple-unit street inlet shall be decreased with respect to the length of the inlet. Linearly applying a single-unit clogging factor to a multiple-unit inlet leads to an excessive increase in length.

With the concept of first-flush volume, the decay of clogging factor to curb opening length is described as (Guo 2000a):

$$C = \frac{1}{N} (C_o + eC_o + e^2C_o + e^3C_o + \dots + e^{N-1}C_o) = \frac{C_o}{N} \sum_{i=1}^{i=N} e^{i-1} = \frac{KC_o}{N} \quad \text{(Equation ST-29)}$$

in which:

C = multiple-unit clogging factor for an inlet with multiple units

C_o = single-unit clogging factor (50% - grate in a sump, 30% - combination in a sump, 20% - curb-opening in a sump, 25% - grate & combination on-grade)

e = decay ratio less than unity, 0.5 for grate inlet, 0.25 for curb-opening inlet

N = number of units

K = clogging coefficient from [Table ST-8](#)

Table ST-8 — Clogging Coefficients and Clogging Factor to apply to Multiple Units (UDFCD USDCM 2002)

N	Grate Inlet		Curb Opening Inlet		Combination	
	K	C	K	C	K	C
1	1.00	0.50	1.00	0.20	1.00	0.30
2	1.50	0.38	1.25	0.13		
3	1.75	0.29	1.31	0.09		
4	1.88	0.24	1.33	0.07		
5	1.94	0.19	1.33	0.05		
6	1.97	0.16	1.33	0.04		
7	1.98	0.14	1.33	0.04		
8	1.99	0.12	1.33	0.03		
> 8	2.00	T.B.D.	1.33	T.B.D.		

Note: This table is generated by Equation ST-29 with $e = 0.5$ and $e = 0.25$.

The interception of an inlet on a grade is proportional to the inlet length, and in a sump is proportional to the inlet opening area. Therefore, a clogging factor shall be applied to the length of the inlet on a grade as:

$$L_e = (1 - C)L \quad \text{(Equation ST-30)}$$

in which L_e = effective (unclogged) length. Similarly, a clogging factor shall be applied to the opening area of an inlet in a sump as:

$$A_e = (1 - C)A \quad \text{(Equation ST-31)}$$

in which:

A_e = effective opening area

A = opening area

2.4 Inlet Location and Spacing on Continuous Grades

2.4.1 Introduction

Locating (or positioning) stormwater inlets rarely requires design computations. Inlets are simply required in certain locations based upon street design/layout considerations, topography (sumps and flat longitudinal grades), and local ordinances. The one exception is that a combination of design computations are required to locate and space inlets on continuous grades. On long, continuous grades, stormwater flow increases as it moves down the gutter and picks up more drainage area. As the flow in the gutter increases, so does the spread. Since there is a specified range for spread (encroachment) allowed for specific street classes, inlets must be strategically placed to remove some of the stormwater from the street. Locating these inlets requires detailed design computations by the design engineer.

2.4.2 Design Considerations

The primary design consideration for the location and spacing of inlets on continuous grades is the spread limitation. This was addressed in [Section 2.3](#). [Table ST-1](#) lists pavement encroachment standards for minor storms in the City of Rogers.

Proper design of stormwater collection and conveyance systems makes optimum use of the conveyance capabilities of street gutters. In other words, an inlet is not needed until the spread reaches its allowable limit during the design storm (10-year frequency). To place an inlet prior to that point on the street is not economically efficient. To place an inlet after that point would violate the encroachment standards. Therefore, the primary design objective is to position inlets along a continuous grade at the locations where the allowable spread is about to be exceeded for the design storm.

Additionally, it is important to consider the type of inlet and its location when designing and positioning inlets. As outlined in [Section 2.1](#) ([Table ST-5](#)), certain inlets (e.g., curb opening inlets) function better than others at avoiding clogging, while others are capable of efficiently capturing water over a wider range of grades (grated inlets). In order to achieve an economic design it is important to utilize the correct inlet type for the specific site constraints.

2.4.3 Design Procedure

Due to the complexity and steps involved in designing inlets, a step-by-step procedure is provided below to aid the design engineer. The steps are typical for most design instances, but may not represent every inlet design scenario. Because of this it is acceptable for the design engineer to veer from the order of the outline as shown below when needed. Additionally, the design spreadsheets and sample problems related to inlet design provide useful information and tools. The general steps for inlet design are:

- 1) Place inlets at locations where they are required as a result of the roadway’s geometry and adjacent land features (i.e. low points in the gutter grade, median breaks, before intersections and crosswalks, etc.).
- 2) Using [Table ST-1](#) in [Section 1.2](#) of this chapter, determine the encroachment limit for the type of street function and classification considered in the design.
- 3) Based on the maximum encroachment limit determined in Step 2, the allowable street hydraulic capacity (peak flow rate in street and gutter) can be determined using [Equation ST-11](#) or [Equation ST-12](#).
- 4) Equate the peak flow rate calculated in Step 3 to a hydrologic method that incorporates the area and characteristics of the drainage area. Through this relationship, the inlet under design can be positioned on the street so that it will serve a specific drainage area. Typically the Rational method is most often used to determine the requisite drainage area. The Rational method was discussed in Chapter 4 – *Determination of Stormwater Runoff* and is repeated here for convenience.

$$Q = C * I * A \qquad \qquad \qquad \text{(Equation ST-32)}$$

in which:

Q = peak discharge (cfs)

C = runoff coefficient described in Table RO-2 and Table RO-3 of Chapter 4 – *Determination of Stormwater Runoff*

I = design storm rainfall intensity (in/hr) described in Table RO-5 of Chapter 4 – *Determination of Stormwater Runoff*

A = drainage area (acres)

The drainage area (A) will be the unknown variable to solve for in [Equation ST-32](#). Runoff coefficient (C) and rainfall intensity (I) shall be determined as discussed in Chapter 4 – *Determination of Stormwater Runoff* of this *Manual*. Then, at the upstream end of the project drainage basin, outline a subarea that correlates to the peak flow rate outlined in Step 3 and the area parameter defined in this Step.

DRAINAGE CRITERIA MANUAL

- 5) Position an inlet along the street in a location that will prevent the allowable encroachment from being exceeded. The idea is to position the inlet at the location where the allowable encroachment is about to reach its allowable limit.
- 6) Specify inlet type and size based on the grade and location where the inlet is to be placed, the amount and velocity of gutter flow, and the resulting spreads. The initial inlet specification (size and type) will be a best guess as the next step in the design process will be to evaluate the specified inlet. (Note: an iterative process is required to achieve an inlet design (type and size) that will satisfy the requirements needed for street drainage)
- 7) Assess the hydraulic capacity of the inlet specified and calculate the inlet efficiency. Repeat Steps 6 and 7 as needed to achieve an inlet design that provides the desired inlet functionality at the location the inlet is required. Generally, an inlet will not capture all of the gutter flow. In fact, it is uneconomical to size an inlet (on continuous grades) large enough to capture all of the gutter flow. Instead, some carryover flow is expected.
- 8) Position another inlet (if needed) along the street downstream from the first inlet to capture runoff from other local drainage areas until a complete system of inlets has been designed that satisfies the allowable street encroachment limit. Utilize the same steps as above while accounting for carryover from one inlet to the next. The gutter discharge for inlets, other than the first inlet, consists of the carryover from the upstream inlet plus the stormwater runoff generated from the intervening local drainage area. The resulting peak flow is approximate since the carryover flow peak and the local runoff peak do not necessarily coincide. The important concept to recognize here is that the carryover reduces the amount of new flow that can be picked up at the next downstream inlet.
- 9) After a complete system of inlets has been established, modification should be made to accommodate special situations such as point sources of large quantities of runoff, and variation of street alignments and grades.

3.0 STORM SEWERS

3.1 Introduction

Once stormwater runoff is collected from the street surface and local watershed areas and captured by an inlet, the water is conveyed through the storm sewer system. The storm sewer system is comprised of inlets, manholes, pipes, bends, outlets, and other appurtenances. The stormwater passes through these components and is discharged into a stormwater management device for mitigation purposes, such as a detention pond or wetland, or discharged directly to an open channel or other waterbody. This section addresses the combination of storm sewer features and how they interrelate to convey stormwater to an outlet.

3.2 Storm Sewer System Components

3.2.1 Inlets

Inlets are the most common stormwater runoff capturing device within a storm sewer system. Design of these structures was outlined in [Section 2](#) of this chapter. As previously described, the primary function of inlets is to collect stormwater runoff to prevent flowing stormwater in streets from becoming a hazard to drivers as well as preventing flood damage to structures adjacent to areas where stormwater is collected.

3.2.2 Junction Boxes

Apart from inlets, junction boxes are the most common component in storm sewer systems. The main difference between inlets and junction boxes is that an inlet's primary function is to collect stormwater runoff. Junction boxes on the other hand are purely for access and transition uses. Their primary functions include:

- Providing maintenance access.
- Providing ventilation.
- Serving as junctions when two or more pipes merge.
- Providing flow transitions for changes in pipe size, slope, and alignment.

Inlets serve in the above capacities as well with the added benefit of also collecting stormwater runoff.

3.2.3 Storm Sewer Pipe

Storm sewer piping is the conduit within the storm sewer system which conveys stormwater collected by inlets to an outlet. Storm sewer piping must be sized to work in conjunction with inlets so that the capacity of the storm sewer is consistent throughout all areas of its design. The sizing of storm sewer piping is described in this section and further analysis and design are provided herein.

3.2.4 Bends and Transitions

Bends and transitions are components utilized to facilitate a change in the alignment or size of storm sewer piping within a storm sewer system. Bends and transitions are an important component in minimizing energy losses within the system when transitions in alignment and size are needed. Bends and transitions without the use of a junction box are subject to City approval.

3.2.5 Outlets

Outlet structures are transitions from pipe flow into open channel flow or still water (e.g., ponds, lakes, etc.). The primary function of outlets is to control the flow and resulting force of stormwater exiting the storm sewer system in order to minimize the erosion potential in the receiving water body. Outlet designs are discussed in Chapter 8 – *Culvert and Bridge Hydraulic Design*; Section 6.0 – Outlet Protection. Additional information on designing outlets can be found in FHWA's [HEC-11](#) (1989) and [HEC-14](#), 3rd Ed. (2006).

3.3 Design Process, Considerations, and Constraints

The design of a storm sewer system requires the collection and evaluation of multiple pieces of information concerning the existing conditions of the study area. Required information includes topography, drainage/watershed boundaries, soil types, impervious surface areas, and locations of any existing storm sewers, inlets, and junction boxes and their sizes. In addition, it is necessary to identify the type and location of existing utilities. With the information described above it is possible to accurately examine proposed layouts of a new storm sewer system or adjustments to an existing system.

When looking at proposed layouts for a storm sewer system each conceptual layout plan shall show inlet and manhole locations, drainage boundaries serviced by each inlet, storm sewer locations, flow directions, and outlet locations. Emphasis should be placed on how the proposed layout interfaces with the existing right-of-way and site topography as these two factors greatly affect the cost of any new storm sewer construction or renovations of an existing system.

Once a final layout is chosen, storm sewers are sized using hydrologic techniques (to determine peak flows generated by the watershed) and hydraulic analysis (to determine pipe capacities). The constraints discussed below and the following design methods shall be used to evaluate the design requirements of a proposed storm sewer system with respect to the design storm.

3.3.1 Storm Sewer Pipe

3.3.1.1 Design Storm Accommodation

Closed storm sewers for all conditions, other than required for major drainage ways as discussed in Chapter 8 – *Culvert and Bridge Hydraulic Design*, shall be designed to accommodate the 10-year design storm, based on the stormwater runoff collected and conveyed by the storm sewer system. Accommodating the design storm means the storm sewer shall be sized to convey collected runoff without surcharging using approved drainage design practices within this *Manual*. All storm sewer shall be designed so that the hydraulic gradient is 2-foot below the ground surface (gutterline) for the entire length of the storm sewer run. The storm sewer shall also be designed so that it conveys at a maximum 80% full flow capacity during the 10-year design storm. Furthermore, all storm sewer must be able to manage the 100-year design storm runoff so that it is conveyed within the right-of-way or a drainage easement at all times and adjacent properties are protected from damage.

3.3.1.2 Size

Industry standard pipe sizes shall be used for all storm sewer piping within the system with no pipe being less than 18-inches in diameter. Pipe sizes generally increase in size moving downstream since the drainage area and corresponding stormwater flows increase. Do not discharge the contents of a larger pipe into a smaller one, even when the capacity of a smaller downstream pipe has sufficient capacity to handle the flow due to a steeper slope.

3.3.1.3 Material

Reinforced concrete pipe (RCP) shall be used in all right-of-way areas and under all traffic areas (including parking lots, driveways, etc.). All storm sewer pipe having a diameter or hydraulically equivalent pipe size diameter of 18-inches or greater must be RCP. RCP ASTM Class III shall be used in all areas unless otherwise required due to fill heights; use ARDOT standards to determine.

RCP shall conform to:

Circular Pipe – AASHTO M170/ASTM C76

Arch-shaped Pipe – AASHTO M206/ASTM C506

Elliptical Pipe – AASHTO M207/ASTM C507.

Corrugated metal pipe (CMP) [including smooth lined (SLCMP)] can only be used in situations where it is not draining off-site properties and must be approved by the City prior to its use. CMP up to 18-inches in diameter can be used in areas outside of the right-of-way and outside of City drainage easements. CMP shall not be used to convey water through a development from properties upstream and on properties where drainage structures are maintained by a residential POA. CMP shall have a minimum cover of 2-feet. CMP shall conform to shall conform to the following:

Galvanized Steel – AASHTO M218/ASTM A929; AASHTO M36/ASTM A760 and AASHTO Section 12/ASTM A796

Aluminized Steel Type 2 – AASHTO M274/ASTM A929; AASHTO M36/ASTM A760 and AASHTO Section 12/ASTM A796

Aluminum – AASHTO M197/ASTM B744; AASHTO M196/ASTM B745 and AASHTO Section 12/ASTM B790.

Corrugated polyethylene pipe (CPP) [including smooth lined (SLCPP)] can only be used in situations where it is not draining off-site properties and must be approved by the City prior to its use. CPP up to 18-inches in diameter can be used in areas outside of the right-of-way and outside of City drainage easements. CPP shall not be used to convey water through a development from properties upstream and on properties where drainage structures are maintained by a residential POA. CPP shall have a minimum cover of 2-feet. CPP shall conform to AASHTO M 294, Type S specification or ASTM F2648, ASTM D3350 and ASTM F2306. All pipe shall be installed per manufacturer's specifications.

Reinforced concrete box (RCB), also includes three-sided boxes for these purposes, shall be structurally designed to accommodate earth and live load to be imposed upon the structure. Refer to the Arkansas Department of Transportation's Reinforced Concrete Box Culvert Standard Drawings. When installed within public right of way, all structures shall be capable of withstanding minimum HL-93 loading.

3.3.1.4 Manning's Roughness Coefficients

Manning's roughness coefficients for storm drains are as follows on [Table ST-9](#)

Table ST-9 — Manning’s Roughness Coefficients, n for Storm Drains

Materials of Construction	Design Manning Coefficient (n)
Reinforced Concrete Pipe (and Reinforced Concrete Box)	0.013
Corrugated Metal Pipe <i>Plain or Coated</i>	0.024
<i>Paved Invert</i>	0.020
<i>Smooth lined</i>	0.012
Corrugated Polyethylene Pipe <i>Plain</i>	0.021
<i>Smooth lined</i>	0.012
Polyvinyl Chloride (PVC)	0.010

3.3.1.5 Shape

Approved storm sewer pipe shapes within the storm sewer system are circular, horizontal elliptical, and arch. Circular pipe is the preferred shape for storm sewer piping, however, where used, horizontal elliptical pipe or arch pipe sizes shall be hydraulically equivalent to the round pipe size. Reinforced concrete box culverts are an acceptable storm sewer conduit and shall be designed according to the same requirements and criteria as RCP storm sewer. Refer to Chapter 8 Culvert and Bridge Hydraulic Design for concrete box requirements.

3.3.1.6 Minimum Grades

Storm sewer piping shall operate with flow velocities sufficient to prevent excessive deposition of solid material; otherwise, clogging can result. Storm drains shall be designed to have a minimum flow velocity of 3.0-ft/sec when flowing under its 10-year design storm capacity. This velocity is accepted as producing scour potential when a storm sewer is flowing at its 10-year design storm capacity so that any deposition of solid material within the storm sewer will be cleaned out during the 10-year design storm. Grades for closed storm sewers and open paved channels shall be designed so that the velocity shall be no less than 3.0-ft/sec for the 10-year design storm capacity nor exceed 12-ft/sec for any design storm. The minimum slope for standard construction procedures shall be 0.40 percent. Any variance must be approved by the City Planning Commission.

3.3.2 Curb Inlet/Junction Boxes

Junction box (inlets, as a minimum, serve the same function as a junction box in most instances) locations are evaluated in the system prior to and in conjunction with pipe design. Most junction box locations are dictated by proper design practices. For example, junction boxes are required whenever there is a change in pipe size, alignment, slope, or where two or more pipes merge. Junction boxes are also required along straight sections of pipe for maintenance purposes. The distance between junction boxes is dependent on pipe size. The maximum spacing between junction boxes for various pipe sizes shall be in accordance with the [Table ST-10](#).

Table ST-10 — Inlet / Junction Box Spacing Based on Storm Sewer Pipe Size

Vertical Dimension of Pipe (and equivalent Box Culvert Height) (inches)	Maximum Distance Between Inlet / Junction Boxes and/or Cleanout Points (feet)
18 to 36	400
42 and larger	500

The invert of a pipe leaving a junction box shall be at least 0.1 foot lower than the incoming pipe to ensure positive low flows through the junction box. Whenever possible, match the crown of the pipe elevations when the downstream pipe is larger. All pipe shall be cut flush with the interior of the inlet / junction box and grouted to insure a smooth flow transition.

Approved sizes for junction boxes are 4 to 6 feet in interior diameter/width. [Table ST-11](#) provides standard junction box sizing in accordance with the size of storm sewer pipe that will exit the structure. The widest dimension for horizontal elliptical or arch pipe shall be used when sizing a corresponding junction box. Larger junction boxes may be required when sewer alignments are not straight through or in cases where more than one pipe is connected to the junction box. In instances where more than one storm sewer line goes through a junction box the interior width of the junction box shall at a minimum provide 1-foot (min.) between each storm sewer pipe and 1-foot (min.) between the outside edge of the sewer pipe and interior wall of the junction box.

Manhole rings and lids for junction boxes and curb inlets shall be cast with the words “City of Rogers” and exhibit the fish logo. All rings and lids shall be heavy duty and traffic rated when located in traffic areas.

Table ST-11 — Inlet / Junction Box Sizing

Storm Sewer Pipe Diameter at Outlet End (inches)	Inlet / Junction Box Interior Diameter / Width (feet)
18	4
21 to 42	5
48 to 54	6
60 and larger	To be approved by City
Multiple STS pipes entering structure	Provide 1-foot (min.) between each STS and 6-inches (min.) between the outside edge of the STS and interior wall of the inlet/junction box

3.3.3 Bends and Transitions

Once storm sewers are sized and junction box locations are determined, the performance of the storm sewer system must be evaluated using energy grade line calculations starting at the downstream

DRAINAGE CRITERIA MANUAL

terminus of the system. As stormwater flows through the storm sewer system, it encounters many flow transitions. These transitions include changes in pipe size, slope, and alignment, as well as entrance and exit conditions. All of these transitions produce energy losses, usually expressed as head losses. These losses must be accounted for to ensure that inlets and junction boxes do not surcharge to a significant degree (i.e., produce street flooding). This is accomplished using hydraulic grade line (HGL) calculations as a check on pipe sizes and system losses. If significant surcharging occurs, the pipe diameters shall be increased. High tailwater conditions at the storm sewer outlet may also produce surcharging. This can also be accounted for using HGL calculations. Specific constraints for these items are discussed further in this section. Bends and transitions without the use of junction box are subject to City approval.

3.4 Storm Sewer Hydrology

3.4.1 Peak Runoff Prediction

The Rational method is commonly used to determine the peak flows that storm sewers must be able to convey. It is an appropriate method due to the small drainage areas typically involved. It is also relatively easy to use and provides reasonable estimates of peak runoff. The total drainage area contributing flow to a particular storm sewer is often divided up into smaller subcatchments. The Rational Method is described in Chapter 4 – *Determination of Stormwater Runoff* of this *Manual*.

The first pipe in a storm sewer system is designed using [Equation ST-32](#) to determine the peak flow. Downstream pipes receive flow from the upstream pipes as well as local inflows. The Rational equation applied to the downstream pipes is:

$$Q = I \sum_{j=1}^n C_j A_j$$

(Equation ST-33)
(Equation RO-1)

in which:

I = design rainfall average intensity, over the time of concentration t_c (in/hr)

n = number of subareas above the stormwater pipe

j = drainage subarea

C_j = runoff coefficient of subarea j

A_j = drainage area of subarea j (acres)

With respect to [Equation ST-33](#), it is evident that the peak flow changes at each design point since the time of concentration, and thus the average intensity, changes at each design point. It is also evident that the time of concentration coming from the local inflow may differ from that coming from upstream pipes. Normally, the longest time of concentration is chosen for design purposes. If this is the case, all of the subareas above the design point will be included in [Equation ST-33](#), and it usually produces the largest peak flow. In some cases, the peak flow from a shorter path may produce the greater peak discharge if

the downstream areas are heavily developed. It is good practice to check all alternative flow paths and tributary areas to determine the tributary zone that produces the biggest design flow and use the largest peak discharge rate for storm sewer sizing.

3.5 Storm Sewer Hydraulics (Gravity Flow in Circular Conduits)

3.5.1 Flow Equations and Storm Sewer Sizing

The size of closed storm sewers shall be designed so that their capacity will not be less than the flow rate computed using Manning's equation. Even though storm sewer flow is usually unsteady and non-uniform, for design purposes it is assumed to be steady and uniform at the peak flow rate. This assumption allows for the use of Manning's equation:

$$Q = \frac{1.49}{n} * A * R^{2/3} * S_f^{1/2} \quad \text{(Equation ST-34)}$$

in which:

Q = flow rate (cfs)

n = Manning's roughness coefficient for storm drain (see [Table ST-9](#))

A = flow area (ft²)

R = hydraulic radius (ft)

S_f = friction slope (normally taken as the storm sewer slope) (ft/ft)

For full flow in a circular storm sewer,

$$A = A_f = \frac{\pi * D^2}{4} \quad \text{(Equation ST-35)}$$

$$R = R_f = \frac{D}{4} \quad \text{(Equation ST-36)}$$

in which:

D = pipe diameter (ft)

A_f = flow area at full flow (ft²)

R_f = hydraulic radius at full flow (ft)

If the flow is pressurized (i.e., surcharging at the inlets or junction boxes is occurring), $S_f \neq S_o$ where S_o is the longitudinal bottom slope of the storm sewer. Design of storm sewers in Rogers assumes 80% full flow. This discharge, Q_f , is calculated using:

DRAINAGE CRITERIA MANUAL

$$Q_f = \frac{1.49}{n} * A_f * R_f^{2/3} * S_o^{1/2}$$

(Equation ST-37)

Storm sewers shall be sized to flow 80% full (i.e., as open channels using nearly the full capacity of the pipe) during the design storm (10-yr frequency). The design discharge is determined first using the Rational equation as previously discussed, then the Manning's equation is used (with $S_f = S_o$) to determine the required pipe size. For circular pipes,

$$D_r = \left[\frac{2.16 * n * Q_p}{\sqrt{S_o}} \right]^{3/8}$$

(Equation ST-38)

in which D_r is the minimum size pipe required to convey the design flow and Q_p is peak design flow.

The typical process for sizing storm sewer pipe proceeds as follows. Initial storm sewer sizing is performed first using the Rational equation ([Equation ST-33](#)) in conjunction with Manning's equation ([Equation ST-37](#)). The Rational equation is used to determine the peak discharge that storm sewers must convey. The storm sewers are then initially sized using Manning's equation assuming uniform, steady flow at the peak. Finally, these initial pipe sizes are checked using the energy equation by accounting for all head losses. If the energy computations detect surcharging at manholes or inlets, the pipe sizes are increased, and the process is repeated as necessary to obtain a solution where surcharging is avoided.

3.5.2 Energy Grade Line and Head Losses

Head losses must be accounted for in the design of storm sewers in order to find the energy grade line (EGL) and the hydraulic grade line (HGL) at any point in the system. The FHWA (1996) gives the following general equation as the basis for calculating the head losses at inlets and junction boxes (h_{LM} , in feet):

$$h_{LM} = K_o * C_D * C_d * C_Q * C_p * C_B * \left(\frac{V_o^2}{2 * g} \right)$$

(Equation ST-39)

in which:

K_o = initial loss coefficient

V_o = velocity in the outflow pipe (ft/sec)

g = gravitational acceleration (32.2 ft/sec²)

C_D , C_d , C_Q , C_p , and C_B = correction factors for pipe size, flow depth, relative flow, plunging flow and benching

However, this equation is valid only if the water level in the receiving inlet or junction box is above the invert of the incoming pipe. Otherwise, another protocol has to be used to calculate head losses at

junction boxes. A modified FHWA procedure is provided that the design engineer can use to calculate the head losses and the EGL along any point in a storm sewer system.

The EGL represents the energy slope between the two adjacent junction boxes in a storm sewer system. A junction box may have multiple incoming storm sewers, but only one outgoing sewer. Each storm sewer and its downstream and upstream junction boxes form a “storm sewer-junction box” unit. The entire storm sewer system can be broken down into a series of “storm sewer-junction box” units that satisfy the energy conservation principle. The computation of the EGL does this by repeating the energy-balancing process for each “storm sewer-junction box” unit.

As illustrated in [Figure ST-11](#), a “storm sewer-junction box” unit has four distinctive sections. Section 1 represents the downstream junction box, Section 2 is the point at the exit of the incoming storm sewer just as enters this junction box, Section 3 is at the entrance to this storm sewer at the upstream junction box, and Section 4 represents the upstream junction box. For each “storm sewer-junction box” unit, the head losses are determined separately in two parts as:

Friction losses through the storm sewer pipe, and juncture losses at the junction box.

Calculation of the EGL through each “storm sewer-junction box” unit is described in the following sections.

In cases where a downstream tailwater condition may exist for which there is no information, e.g. discharging into an existing storm sewer system or ditch, it shall be assumed that the existing pipe or ditch is flowing full for the design storm event.

3.5.2.1 Losses at the Downstream Junction Box—Section 1 to Section 2

The continuity of the EGL is determined between the flow conditions at centerline of the downstream junction box, Section 1, and the exit of the incoming storm sewer, Section 2, as illustrated in [Figure ST-11](#) and an idealized EGL and HGL profiles in [Figure ST-12](#).

At Section 2 there may be pipe-full flow, critical/supercritical open channel flow, or sub-critical open channel flow. If the storm sewer crown at the exit is submerged, the EGL at the downstream junction box provides a tailwater condition; otherwise, the junction box drop can create a discontinuity in the EGL. Therefore, it is necessary to evaluate the two possibilities, namely:

$$E_2 = \text{Max} \left(\frac{V_2^2}{2 * g} + Y_2 + Z_2, E_1 \right) \tag{Equation ST-40}$$

in which:

E_2 = EGL at Section 2

V_2 = storm sewer exit velocity (ft/sec)

Y_2 = flow depth at the storm sewer exit (feet)

DRAINAGE CRITERIA MANUAL

Z_2 = invert elevation at the storm sewer exit (feet)

E_1 = tailwater at Section 1 (feet)

[Equation ST-40](#) states that the highest EGL value shall be considered as the downstream condition. If the junction box drop dictates the flow condition at Section 2, a discontinuity is introduced into the EGL.

Figure ST-11 — A Storm Sewer-Junction Box Unit (UDFCD USDCM 2002)

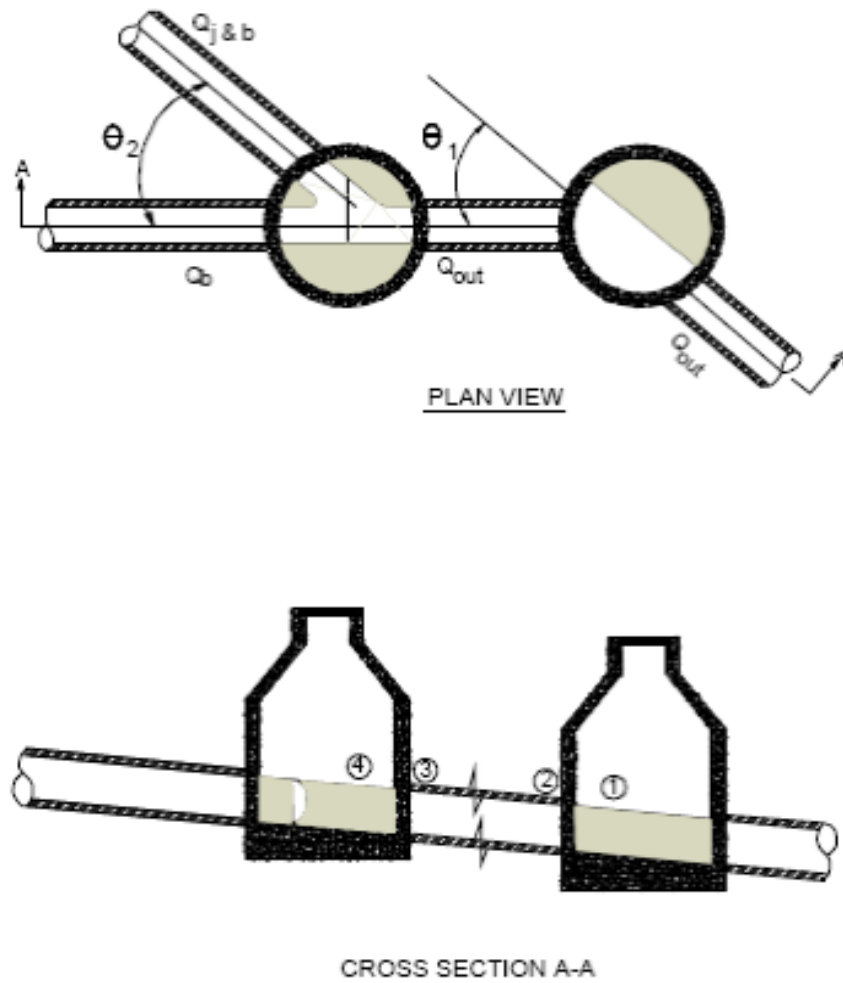
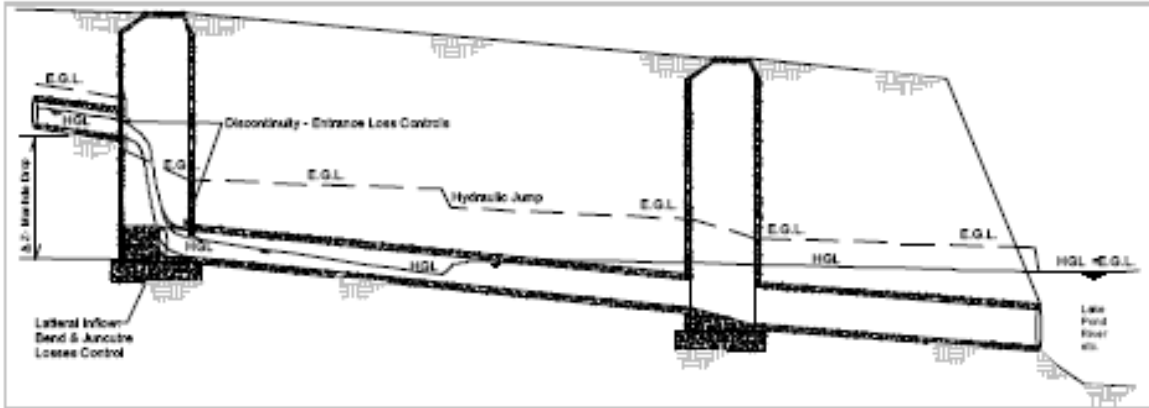

Figure ST-12 — Hydraulic and Energy Grade Lines (UDFCD USDCM 2002)



3.5.2.2 Losses in the Pipe, Section 2 to Section 3.

The continuity of the EGL upstream of the junction box depends on the friction losses through the storm sewer pipe. The flow in the storm sewer pipe can be one condition or a combination of open channel flow, full flow, or pressurized (surcharge) flow.

When a free surface exists through the pipe length, the open channel hydraulics apply to the backwater surface profile computations. The friction losses through the storm sewer pipe are the primary head losses for the type of water surface profile in the storm sewer. For instance, the storm sewer pipe carrying a subcritical flow may have an M-1 water surface profile if the water depth at the downstream junction box is greater than normal depth in the storm sewer or an M-2 water surface profile if the water depth in the downstream junction box is lower than normal depth. Under an alternate condition, the pipe carrying a supercritical flow may have an S-2 water surface profile if the pipe entering the downstream junction box is not submerged; otherwise, a hydraulic jump is possible within the storm sewer.

When the downstream storm sewer crown is submerged to a degree that the entire storm sewer pipe is under the HGL, the head loss for this full flow condition is estimated by pressure flow hydraulics.

When the downstream storm sewer crown is slightly submerged, the downstream end of the storm sewer pipe is surcharged, but the upstream end of the storm sewer pipe can have open channel flow. The head loss through a surcharge flow depends on the flow regime. For a subcritical flow, the head loss is the sum of the friction losses for the full flow condition and for the open channel flow condition. For a supercritical flow, the head loss may involve a hydraulic jump. To resolve which condition governs, culvert hydraulic principles can be used under both inlet and outlet control conditions and the governing condition is the one that produces the highest HGL at the upstream junction box.

Having identified the type of flow in the storm sewer pipe, the computation of friction losses begins with the determination of friction slope. The friction loss and energy balance are calculated as:

$$h_f = L * S_f \tag{Equation ST-41}$$

$$E_3 = E_2 + \sum h_f \quad \text{(Equation ST-42)}$$

in which:

h_f = friction loss

L = length of storm sewer pipe (feet)

S_f = friction slope in the pipe (ft/ft)

E_3 = EGL at the upstream end of storm sewer pipe (feet)

3.5.2.3 Losses at the Upstream Junction Box, Section 3 to Section 4

Additional losses may be introduced at the storm sewer entrance. Based on the general head loss equation shown in [Equation ST-39](#), the general formula to estimate the entrance loss is:

$$h_E = K_E * \frac{V^2}{2 * g} \quad \text{(Equation ST-43)}$$

in which:

h_E = entrance loss (feet)

V = pipe-full velocity in the incoming storm sewer (ft/sec)

K_E = entrance loss coefficient (see [Table ST-12](#))

In the modeling of storm sewer flow, the storm sewer entrance coefficients can be assumed to be part of the bend loss coefficient.

The energy principle between Sections 3 and 4 is determined by:

$$E_4 = E_3 + h_E \quad \text{(Equation ST-44)}$$

in which E_4 = EGL at Section 4.

**Table ST-12 — Entrance Loss Coefficients for Outlet Control,
Full or Partly Full Flow
(FHWA – HDS-5 2005)**

<u>Type of Structure and Design of Entrance</u>	<u>Coefficient K_e</u>
• <u>Pipe, Concrete</u>	
Projecting from fill, socket end (groove-end)	0.2
Projecting from fill, sq. cut end	0.5
Headwall or headwall and wingwalls	
Socket end of pipe (groove-end)	0.2
Square-edge	0.5
Rounded (radius = $D/12$)	0.2
Mitered to conform to fill slope	0.7
*End-Section conforming to fill slope	0.5
Beveled edges, 33.7° or 45° bevels	0.2
Side- or slope-tapered inlet	0.2
• <u>Pipe. or Pipe-Arch. Corrugated Metal</u>	
Projecting from fill (no headwall)	0.9
Headwall or headwall and wingwalls square-edge	0.5
Mitered to conform to fill slope, paved or unpaved slope	0.7
*End-Section conforming to fill slope	0.5
Beveled edges, 33.7° or 45° bevels	0.2
Side- or slope-tapered inlet	0.2
• <u>Box, Reinforced Concrete</u>	
Headwall parallel to embankment (no wingwalls)	
Square-edged on 3 edges	0.5
Rounded on 3 edges to radius of $D/12$ or $B/12$	
or beveled edges on 3 sides	0.2
Wingwalls at 30° to 75° to barrel	
Square-edged at crown	0.4
Crown edge rounded to radius of $D/12$ or beveled top edge	0.2
Wingwall at 10° to 25° to barrel	
Square-edged at crown	0.5
Wingwalls parallel (extension of sides)	
Square-edged at crown	0.7
Side- or slope-tapered inlet	0.2

*Note: "End Sections conforming to fill slope," made of either metal or concrete, are the sections commonly available from manufacturers. From limited hydraulic tests they are equivalent in operation to a headwall in both inlet and outlet control. Some end sections, incorporating a closed taper in their design have a superior hydraulic performance. These latter sections can be designed using the information given for the beveled inlet.

3.5.2.4 Juncture and Bend Losses at the Upstream Junction Box, Section 4 to Section 1

The analysis from Section 4 of the downstream "storm sewer-junction box" unit to Section 1 of the upstream "storm sewer-junction box" unit consists only of juncture losses through the junction box. To maintain the conservation of energy through the junction box, the outgoing energy plus the energy losses

DRAINAGE CRITERIA MANUAL

at the junction box have to equal the incoming energy. Often a junction box is installed for the purpose of maintenance, deflection of the storm sewer line, change of the pipe size, and as a juncture for incoming laterals. Although there are different causes for juncture losses, they are often, rightly or wrongly, considered as a minor loss in the computation of the EGL. These juncture losses in the storm sewer system are determined solely by the local configuration and geometry and not by the length of flow in the junction box.

3.5.2.4.1 Bend/Deflection Losses

The angle between the incoming sewer line and the centerline of the exiting main storm sewer line introduces a bend loss to the incoming storm sewer. Based on the general head loss equation shown in [Equation ST-39](#), bend loss is estimated by:

$$h_b = K_b * \frac{V^2}{2 * g} \quad \text{(Equation ST-45)}$$

in which:

h_b = bend loss (feet)

V = full flow velocity in the incoming storm sewer (ft/sec)

K_b = bend loss coefficient

As shown in [Figure ST-13](#) and [Table ST-13](#), the value of K_b depends on the angle between the exiting storm sewer line and the existence of junction box bottom shaping. A shaped junction box bottom or a deflector guides the flow and reduces bend loss. [Figure ST-14](#) illustrates four cross-section options for the shaping of a junction box bottom. Only sections “c. Half” and “d. Full” can be considered for the purpose of using the bend loss coefficient for the curve on [Figure ST-13](#) labeled as “Bend at Manhole, Curved or Shaped.”

Because a junction box may have multiple incoming storm sewer lines, [Equation ST-45](#) shall be applied to each incoming storm sewer line based on its incoming angle, and then the energy principle between Sections 4 and 1 is calculated as:

$$E_1 = E_4 + h_b \quad \text{(Equation ST-46)}$$

3.5.2.4.2 Lateral Juncture Losses

In addition to the bend loss, the lateral juncture loss is also introduced because of the added turbulence and eddies from the lateral incoming flows. Based on the general head loss equation shown in [Equation ST-39](#), the lateral juncture loss is estimated as:

$$h_j = \frac{V_o^2}{2 * g} - K_j \frac{V_i^2}{2 * g}$$

(Equation ST-47)

in which:

h_j = lateral loss (feet)

V_o = full flow velocity in the outgoing storm sewer (ft/sec)

K_j = lateral loss coefficient

V_i = full flow velocity in the incoming storm sewer (ft/sec)

In modeling, a manhole can have multiple incoming storm sewer lines, one of which is the main (i.e., trunk) line, and one outgoing storm sewer line (see [Figure ST-11](#)). As shown in [Table ST-13](#), the value of K_j is determined by the angle between the lateral incoming storm sewer line and the outgoing storm sewer line.

Table ST-13 — Bend Loss and Lateral Loss Coefficients (FHWA – HEC-22 2001)

Angle in Degree (θ)	Bend Loss Coefficient (K_b) Curved Deflector at the Junction Box	Bend Loss Coefficient (K_b) Non-shaping Junction Box	Lateral Loss Coefficient (K_j) Main Line Storm Sewer
Straight Through	0.05	0.05	Not Applicable
22.50	0.10	0.13	0.75
45.00	0.28	0.38	0.50
60.00	0.48	0.63	0.35
90.00	1.01	1.32	0.25
Angles greater than 90.00 are not allowed.			

At a junction box, the engineer needs to identify the main incoming storm sewer line (the one that has the largest inflow rate) and determine the value of K_j for each lateral incoming storm sewer line. To be conservative, the smallest K_j is recommended for [Equation ST-47](#), and the lateral loss is to be added to the outfall of the incoming main line storm sewer as:

$$E_1 = E_4 + h_b + h_j \quad (h_j \text{ is applied to the main storm sewer line only}) \text{ (Equation ST-48)}$$

The difference between the EGL and the HGL is the flow velocity head. The HGL at a junction box is calculated by:

$$H_1 = E_1 - \frac{V_o^2}{2 * g}$$

(Equation ST-49)

The energy loss between two junction boxes is defined as:

$$\Delta E = (E_1)_{upstream} - (E_1)_{downstream}$$

(Equation ST-50)

in which ΔE = energy loss between two junction boxes. It is noted that ΔE includes the friction loss, juncture loss, bend loss, and junction box drop.

3.5.2.5 Transitions

In addition to “storm sewer-junction box” unit losses, head losses in a storm sewer can occur due to a transition in the pipe itself, namely, gradual pipe expansion. Based on the general head loss equation shown in [Equation ST-39](#), transition loss, h_{LE} , in feet, can be determined using:

$$h_{LE} = K_e \left(\frac{V_1^2}{2 * g} - \frac{V_2^2}{2 * g} \right)$$

(Equation ST-51)

in which K_e is the expansion coefficient and subscripts 1 and 2 refer to upstream and downstream of the transition, respectively. The value of the expansion coefficient, K_e , may be taken from [Table ST-14](#) for free surface flow conditions in which the angle of cone refers to the angle between the sides of the tapering section (see [Figure ST-15](#)).

Table ST-14 — Head Loss Expansion Coefficients (K_e) in Non-Pressure Flow (FHWA – HEC-22 2009)

D_2/D_1	Angle of Cone						
	10°	20°	45°	60°	90°	120°	180°
1.5	0.17	0.40	1.06	1.21	1.14	1.07	1.00
3	0.17	0.40	0.86	1.02	1.06	1.04	1.00

This *Manual* does **NOT** allow pipe contractions within new storm sewers. The following table is provided for evaluating existing storm sewers where contractions may be present.

Table ST-15 — Typical Values for Sudden Pipe Contractions (K_c) (FHWA – HEC-22 2009)

D_2/D_1	K_c
0.2	0.5
0.4	0.4
0.6	0.3
0.8	0.1
1.0	0.0
D ₂ /D ₁ = Ratio of diameter of smaller pipe to large pipe.	

3.5.2.6 Curved Storm Sewers

Curved storm sewers shall not be used unless specifically approved by City. Derived from the general head loss equation shown in [Equation ST-39](#), head losses due to curved storm sewers (sometimes called radius pipe), h_{Lr} , in feet, can be determined using:

$$h_{Lr} = K_r \frac{V^2}{2 * g}$$

(Equation ST-52)

in which K_r = curved storm sewer coefficient from [Figure ST-13](#).

3.5.2.7 Losses at Storm Sewer Exit

Derived from the general head loss equation shown in [Equation ST-39](#), head losses at storm sewer outlets, h_{LO} , are determined using:

$$h_{LO} = \frac{V_o^2}{2 * g} - \frac{V_d^2}{2 * g}$$

(Equation ST-53)

in which V_o is the velocity in the outlet pipe, and V_d is the velocity in the downstream channel. When the storm sewer discharges into a reservoir or into air because there is no downstream channel, $V_d = 0$ and one full velocity head is lost at the exit.

Figure ST-13 — Bend Loss Coefficients (UDFCD USDCM 2002)

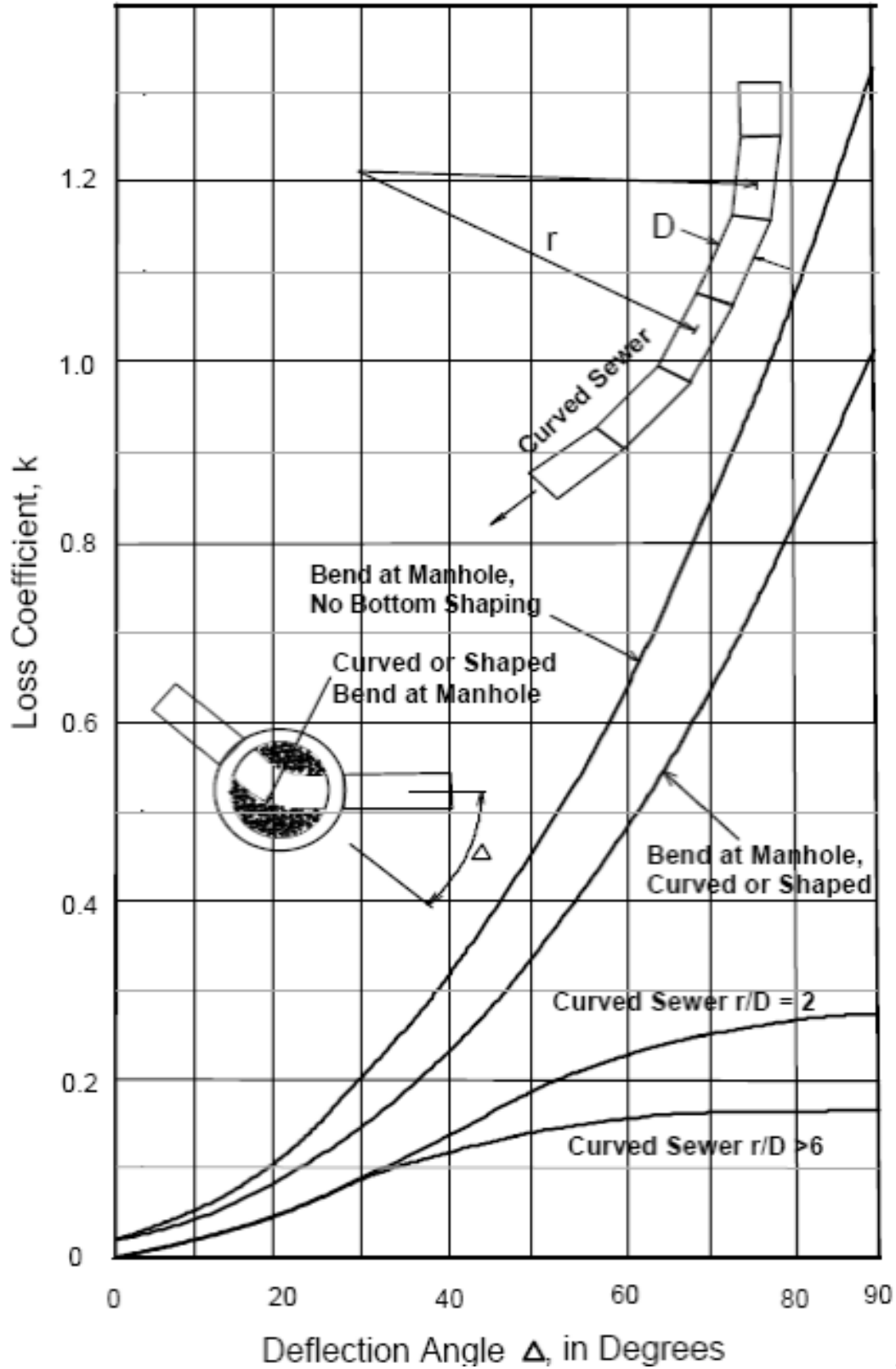

Figure ST-14 — Access Hole Benching Methods (UDFCD USDCM 2002)

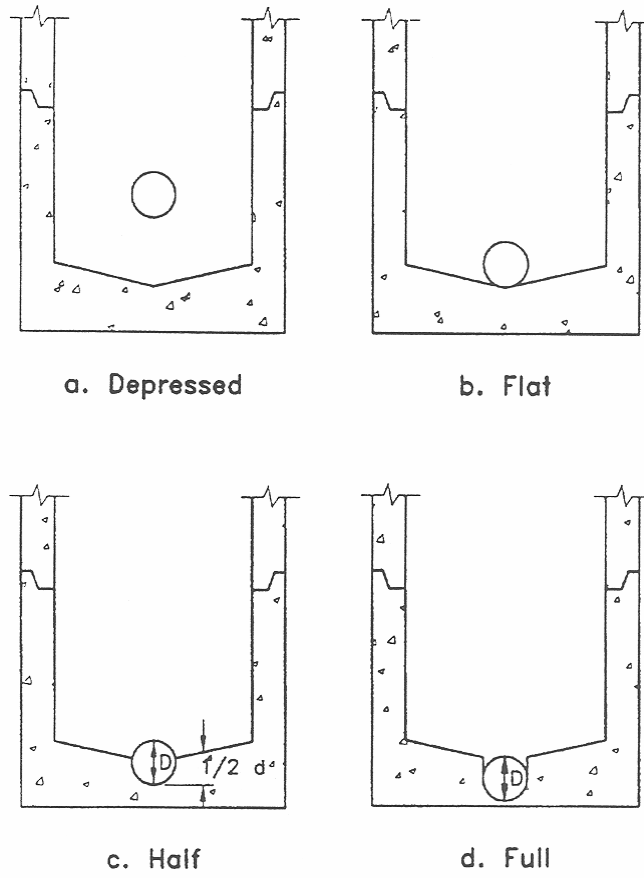
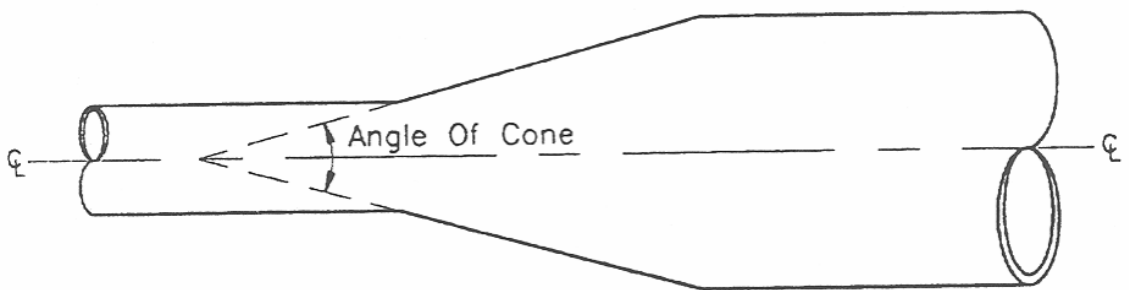

Figure ST-15 — Angle of Cone for Pipe Diameter Changes (FHWA HEC-22 2009)



4.0 REFERENCES

- Akan, A.O. and R.J. Houghtalen. 2002. *Urban Hydrology, Hydraulics, and Water Quality*. Upper Saddle River, NJ: Prentice Hall. Forthcoming.
- American Association of State Highway and Transportation Officials (AASHTO). 1992. *Volume 9, Highway Drainage Guidelines, Storm Drainage System*.
- American Association of State Highway and Transportation Officials, 1991. *Model Drainage Manual*.
- Denver Regional Council of Governments (DRCOG). 1969 (Rev. 1984). *Urban Storm Drainage Criteria Manual (USDCM)*. Denver, CO.
- Federal Highway Administration (FHWA). 1986. *Bridge Deck Drainage Guidelines. FHWA Report No. RD-014*. Washington, DC: Federal Highway Administration.
- Federal Highway Administration. 1961. *Design Charts for Open-Channel Flow*. Hydraulic Design Series No. 3 (HDS-3). Washington, DC: Federal Highway Administration.
- Federal Highway Administration. 1984. *Drainage of Highway Pavements*. Hydraulic Engineering Circular No. 12 (HEC-12). McLean, VA: Federal Highway Administration.
- Federal Highway Administration. 1993. *Design of Bridge Deck Drainage*. Hydraulic Engineering Circular No. 21 (HEC-21). Washington, DC: Federal Highway Administration.
- Federal Highway Administration. 2001. *Urban Drainage Design Manual*. Hydraulic Engineering Circular No. 22 (HEC-22), Second Edition. Washington, DC: Federal Highway Administration.
- Guo, J.C.Y. 1992. *Technical Manual for Computer Model UDSEWER for Storm Sewer System Design*. Denver, CO: Department of Civil Engineering, University of Colorado at Denver.
- Guo, J.C.Y. 1998a. *Storm Sewer System Design and Flow Analysis Using the Personal Computer Model UDSEWER*. Denver, CO: Urban Drainage and Flood Control District.
- Guo, J.C.Y. 1998b. *Street Hydraulics and Inlet Sizing Using the Computer Model UDINLET*. Denver, CO: Urban Drainage and Flood Control District.
- Guo, J.C.Y. 1999. *Storm Water System Design*. CE 5803, University of Colorado at Denver.
- Guo, J.C.Y. 2000a. Design of Grate Inlets with a Clogging Factor. *Advances in Environmental Research* 4(3)181-186.
- Guo, J.C.Y. 2000b. Street Storm Water Conveyance Capacity. *Journal of Irrigation and Drainage Engineering* 136(2)119-124.
- Guo, J.C.Y. 2000c. Street Storm Water Storage Capacity. *Journal of Water Environment Research*, Vol. 27, No. 6. Sept/Oct.
- Guo, J.C.Y. 2006. *Urban Hydrology and Hydraulic Design*. Highlands Ranch, CO: Water Resources Publications, LLC.
- Virginia Department of Transportation (VDOT). 2002. *Drainage Manual, 4th Edition*. Commonwealth of Virginia. Location and Design Division: Hydraulics Section
- Wright-McLaughlin Engineers. 1969. *Urban Storm Drainage Criteria Manual*. Prepared for the Denver Regional Council of Governments. Denver, CO: Urban Drainage and Flood Control District.
- Pavement and Geometric Design Criteria for Minimizing Hydroplaning. FHWA Report No. RD-79-31, December 1979
- Dah-Chen Wood. Public Roads, Vol. 52, No. 2, Bridge Drainage System Needs Criteria. U. S. Department of Transportation, September 1988

DRAINAGE CRITERIA MANUAL

Federal Highway Administration. 1979. *Design of Urban Highway Drainage*. Washington, DC: Federal Highway Administration.